

TESEO®

ALUMINIUM PIPEWORK FLUID POWER DISTRIBUTION SYSTEMS



Square thinking
outside
the box

INDEX

| | | |
|---|-------------|-----------|
| COMPANY PROFILE | Page | 3 |
| Teseo commercial network | Page | 5 |
| HBS Hollow bar system | Page | 16 |
| Hollow bar | Page | 20 |
| Accessories | Page | 21 |
| NPT Accessories | Page | 36 |
| AP Aluminium pipework | Page | 40 |
| Hollow bar | Page | 44 |
| Accessories | Page | 45 |
| NPT Accessories | Page | 58 |
| AP Multifluid 25 bar | Page | 60 |
| ATS Air track supply | Page | 66 |
| Accessories | Page | 69 |
| SAB Swinging arm bracket | Page | 74 |
| Accessories | Page | 76 |
| WBA Workbench for assembly | Page | 78 |
| Accessories | Page | 80 |
| MAT Modular air trolley | Page | 83 |
| AM Aluminium manifold | Page | 85 |
| DT Drilling tool | Page | 86 |
| Manual pipe bender | Page | 87 |
| CA Commercial Accessories | Page | 89 |
| Technical Sheet | Page | 94 |
| HBS-AP Assembling instructions | Page | 97 |

LEGEND

| | | |
|---|-----------------------|--------------------------------------|
| A | mm | Height, dimension |
| B | mm | Width, dimension |
| C | mm | Distance |
| D - d | mm | Diameter |
| E | mm | Hexagon, wrench |
| F | Kg - Nm | Force |
| G | " | Gas thread (BSP or NPT) |
| I - i | mm | Distance between slots |
| J x | cm ⁴ | Moment of inertia along x |
| J y | cm ⁴ | Moment of inertia along y |
| L | mm | Length |
| N° | _ | Code number |
| n° | _ | Quantity number |
| P | g | Weight |
| R | mm | Radius |
| S | mm | Thickness |
| T | - | Threaded hole |
| V | dm ³ | Inside volume |
| α° | ° | Angle |
|  | | Only on request - check availability |

| | |
|---------------------------------------|-----------------------------------|
| HBS Hollow bar system | Swinging arm bracket SAB |
| AP Aluminium pipework | Modular air trolley MAT |
| POW Powered aluminium pipework | Workbench for assembly WBA |
| ATS Air track supply | All systems SYS |

IMPORTANT

The drawings contained in the catalogue are typical and not binding. Teseo Srl are continuously improving products and features and reserves the right to modify design and dimensions at any time.

WARNING!

For the correct application of all Teseo products carefully read the technical data in this catalogue and on our website www.teseoair.com. Thoroughly read the instruction manual before carrying out the installation.

TESEO HISTORY



Teseo SRL was founded in 1988 and initially worked within the textile industry as an industrial supplier and engineering consultants.

During this period they discovered several problems linked to many factory's compressed air distribution systems. The traditional pipework distribution systems, such as Black and Galvanised steel, had many limitations and restrictions for the distribution of Compressed Air such as low flow rates, high pressure drop, corrosion, fluid contamination and major difficulties in modifying the installations.

As a solution to solve these problems, Teseo began to design and develop a modular aluminium pipework system for the distribution of compressed air. In the early 90's Teseo were the first company to successfully develop and bring to market a Modular Aluminium Pipework System specifically designed for the distribution of Compressed Air and other fluids.

Combining the features of a structural profile together with the full flow of a pipe, Teseo achieved one of the most innovative systems for fluid power distribution.

Modern high tech designs, easy to use and flexible were the main features to claim everyone's attention. Afterwards energy efficiency, thanks to the low friction coefficient of the inner surface of the pipes, became an additional advantage compared to the traditional piping systems.

Teseo were pioneers in this new market sector, modular aluminium systems for the distribution of inert gases. There was immediately an excellent feedback from en-



gineering consultants, installers and end users thanks to the wide range of the diameters (from 1/2" up to 4" - 12mm to 110mm internal diameter!) and ease of installation, Teseo soon became the worldwide reference for Compressed Air modular aluminium pipework systems.

Today Teseo is a modern and dynamic company with an active and motivated sales and management team. Our Technical department have a passion for continuously improving and developing our existing range of products, forward thinking and striving to develop new ranges to meet our customers' future needs and requirements.



WHY BUY A TESEO SYSTEM

The choice of a Teseo modern modular piping system in aluminium eliminates the hidden costs of a compressed air system. Such costs are constantly increasing during the entire lifetime of your distribution system. Typical hidden costs eliminated or reduced by Teseo aluminium piping are:

- **Costs for air leaks.** The patented clamping and sealing concept of our piping system eliminates leaks, a major problem in many compressed air systems, Teseo pipework systems saves energy normally wasted in such systems.
- **Costs of air treatment,** in-line Filters, maintenance, repairing machines and tools. Aluminium is not affected by rusting or corrosion, so inside Teseo piping air is always as clean as after the treatment done at the source. This guarantees a longer life to the equipment connected.
- **Costs for downtime and labour for each modification.** A Teseo pipework network is easy to modify and to extend. As a compressed air system inside the factory, adding a new branch line or point of use drop takes few minutes to be operative. These can also be added live using our hot tap.
- **Costs for the low flow rate and high pressure drop.** High precision aluminium extruded profiles of Teseo piping have a smooth inner surface. The friction of air flowing through the tubing is considerably lower than in a conventional rough steel or black steel pipe. Such a feature can be easily translated into less pressure drop and extra flow with the same electric power supply consumption. Contact our sales representative or website to get more information.



TESEO
Systems

TRADITIONAL
Systems

- Hidden costs (Air quality, modifications, low efficiency and air leaks)
- Labour costs
- Material costs

HIGH TECH DESIGN

LIGHT WEIGHT

HEAVY DUTY PROFILES AND ACCESSORIES

100% METAL PIPES & FITTING

100% RECYCLABLE ALUMINIUM

ENERGY SAVING

SAFE AND RELIABLE



SALES NET

Today compressed air is widely used in many different industrial fields, applications range from textile to precision engineering, to automotive and pharmaceutical industry. Through complete plants or simple manifolds, the distribution of compressed air is used in every kind of production activity as service or machine. Aluminium is now the preferred choice for the inert gas distribution among the out dated technology of galvanised steel or welded steel. Due to the growing interest in aluminium solutions, Teseo has developed its own commercial network.

Teseo is managing its products through a national and international network of distributors and qualified installers providing them with a technical and commercial quality support.



ENGINEERING OFFICES AND CONSULTING

Constantly involved in new projects, engineering consultants and engineering offices are working with Teseo to specify and promote fluid power distribution with modular aluminium systems through sizing and technical specifications of complete industrial plants.

BRANCHES AND DISTRIBUTORS

Teseo are constantly improving its own commercial network through branches and distributors to grant the best products and services to suit the needs of our customers (installers, resellers, end users).

Our worldwide net of Teseo contacts is all directed to the customer's satisfaction offering technical assistance and fast delivery from their warehouse.

ITALY:

TESEO SRL

VIA DEGLI OLEANDRI, 1
25015 DESENZANO DEL GARDA
BRESCIA
Tel. +39 030 9150411
Fax +39 030 9150419

SPAIN:

TESEO IBÉRICA AP, S.L.

FRANCESC LAYRET 12-14, NAU 3
08630 ABRERA, BARCELONA
Tel. +34 93 7834730
Fax +34 93 7834538

GERMANY:

TESEO DEUTSCHLAND GMBH

BLEICHSTR. 47
56249 HERSCHBACH
Tel. +49 2626 923225
Fax +49 2626 349255

BENELUX:

TESEO BENELUX B.V.

CACTUSLAAN 9,
1433 GZ KUDELSTAART
Tel. +31 (0) 529 435983

UNITED KINGDOM:

TESEO UK

UNIT 2, HOUSE 5
LYNDERSWOOD FARM, LYNDERSWOOD LANE
BRAintree, ESSEX CM77 8JT
Tel. +44 08701 672150
Fax +44 08701 672151

CANADA:

TESEO CANADA

9315-1041 QUEBEC INC.
310, CHEMIN GENDRON
SHERBROOKE, QUEBEC.
CANADA J1R0J6
Tel. +1 844 823 2179
Fax +1 819 562 2274

FLUID POWER IN THE FACTORY AND ON MACHINERY

Bypass and manifolds for the assembly and installation of compressed air equipment.



Distribution pipework in aluminium for compressed air, nitrogen, vacuum and other inert gases, from 12mm to 110 mm internal diameter.



Drops to the point of use, fast and easy to install or modify.

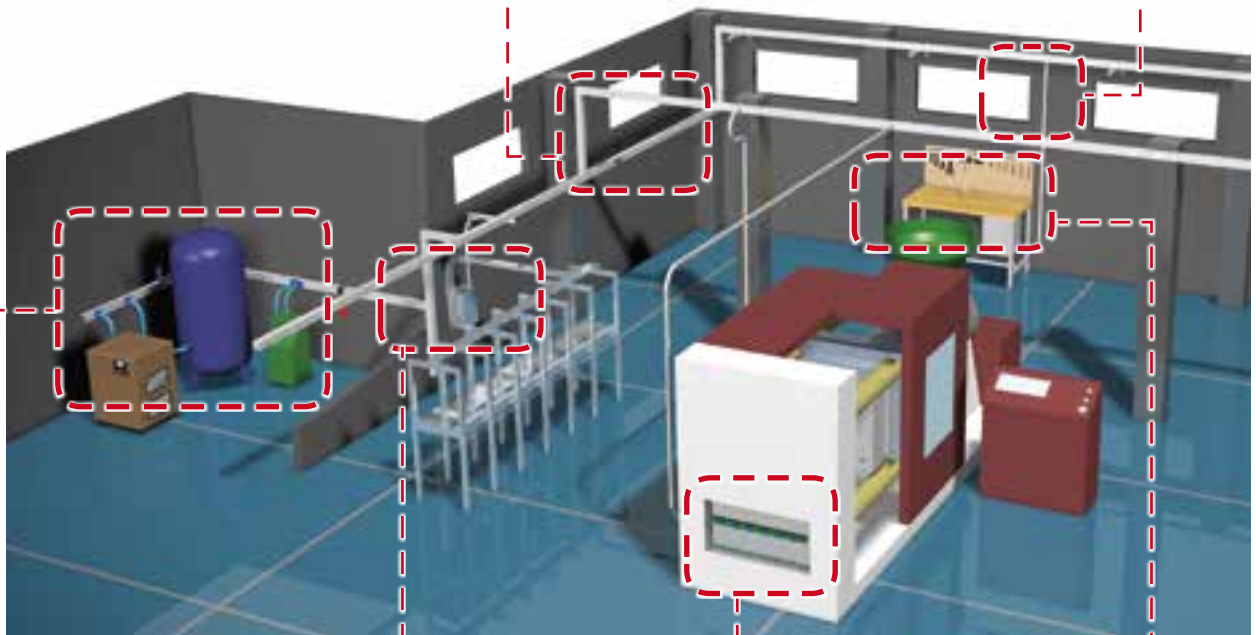

Distribution manifolds integrated on pneumatic control panels for automation.



Modular distribution manifolds on machines or automatic lines.



Feeding lines for pneumatic tools along walls or work benches.

ERGONOMIC SOLUTIONS FOR PNEUMATIC TOOLS

Modular track and trolleys on ATS aluminium rail for compressed air and electrical distribution.



Pressurized SAB pivoting arms in aluminium for feeding tools, covering a wide working radius.



Swinging SAB arms on benches, to support and feed pneumatic tools.

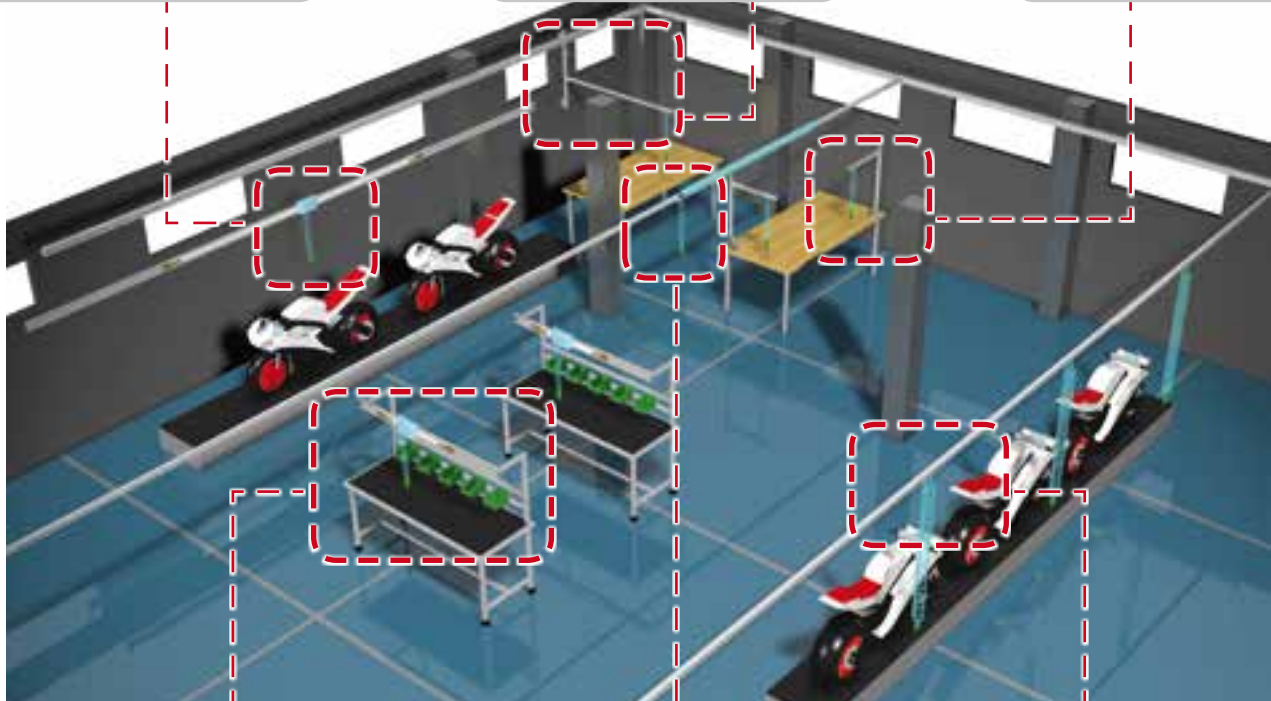

Workbenches for assembly, operated with pneumatic and electrical tools.



MAT Trolley running overhead on the aluminium pipework supporting and feeding pneumatic tools



Assembly and production lines built in Teseo aluminium profiles and glider pads



NATIONAL AND INTERNATIONAL TRADE FAIRS

Trade fairs remain the main means to release new technological trends and news developed by the manufacturers.

As the pioneer of the first modular aluminium piping for fluid power distribution, Teseo has attended many of the most relevant worldwide trade shows achieving worldwide recognition.

During the main fluid power shows, Teseo has received many awards and certificates for innovation, benefits and features of its fluid power distribution system.



PRESS RELEASE

Since the beginning Teseo has invested in communication on technical reviews dedicated to pneumatic and to technical trade magazines, either with advertisements or with press release about applications.

Thanks to the job done in the past, the Teseo brand is now clearly and strongly identified with the concepts of quality, reliability and modularity. With coverage and presence in the most prestigious and well-known worldwide publications.



www.teseoair.com

SOME ON-LINE SERVICES

- @ Area dedicated to products, where you can run advanced searches for components or check their correct coding, and technical data and view explanatory drawings.
- @ Area dedicated to our virtual press office: editorials on our brand and products promotions, like trade fairs reports and publications on specific magazines all over the world.
- @ Area dedicated to case histories and different applications of our products.
- @ Area dedicated to product news, past, present and future significant events.
- @ Dedicated on-line forms are available, fill in to ask for customized products, ask for a quote, place an order or to assemble simple components with more complex ones.
- @ Register on-line and communicate with all of the Teseo departments.
- @ Free design software is available on line in order to size your own plant with Teseo's Aluminium pipework system.
- @ Simple on line software is available to order Teseo parts and fittings, by using a simple and intuitive form.
- @ A complete converter of units of measurement is also available on line.

It is possible to download this Catalogue and many other documents in Acrobat ® PDF format.

AWARDS



WINNER 2007



FINALIST 2006



FINALIST 2006



FINALIST 2006



WINNER 2006



WINNER 2001



WINNER 2000



WINNER 1999



WINNER 1996



WINNER 1992

FROM DESIGN TO THE INSTALLATION

Teseo supports its own partners and customers through the designing and sizing of air lines, the development of customized solutions for machines and production lines. Consulting on standards, information and technical training for installers, assistance during the installation and testing of the system.

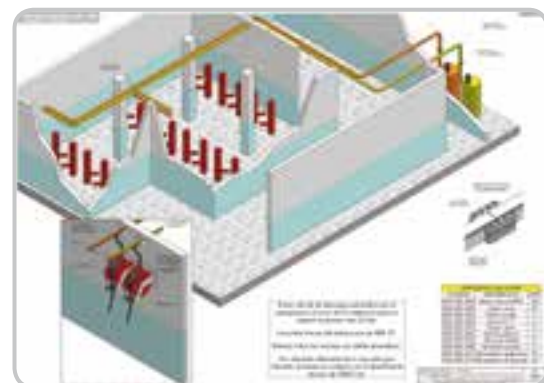
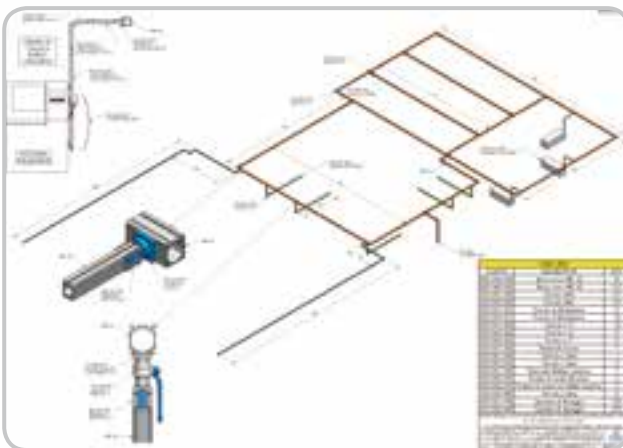
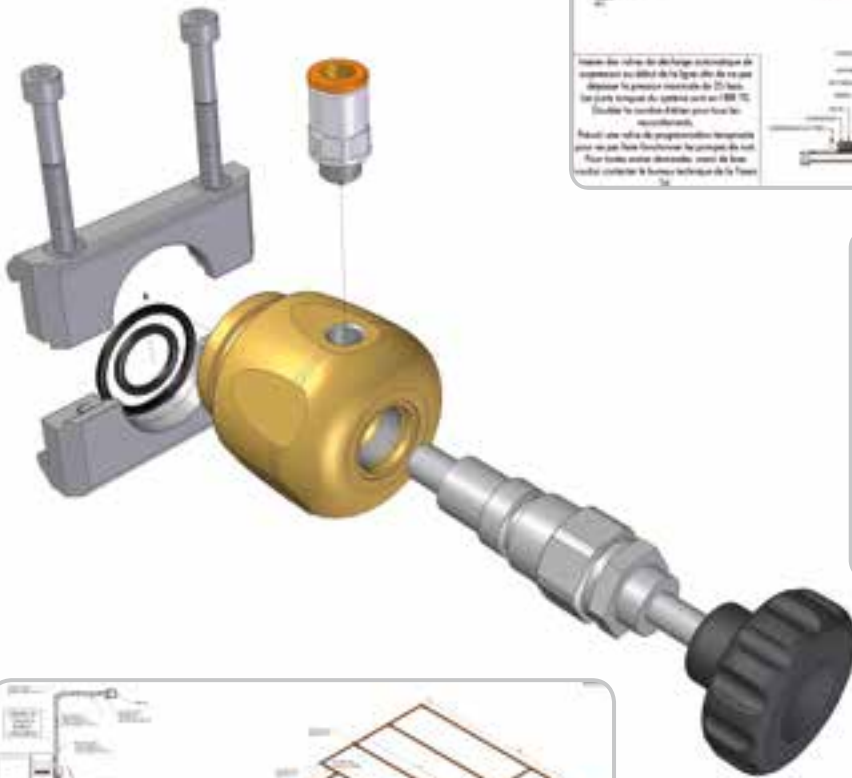
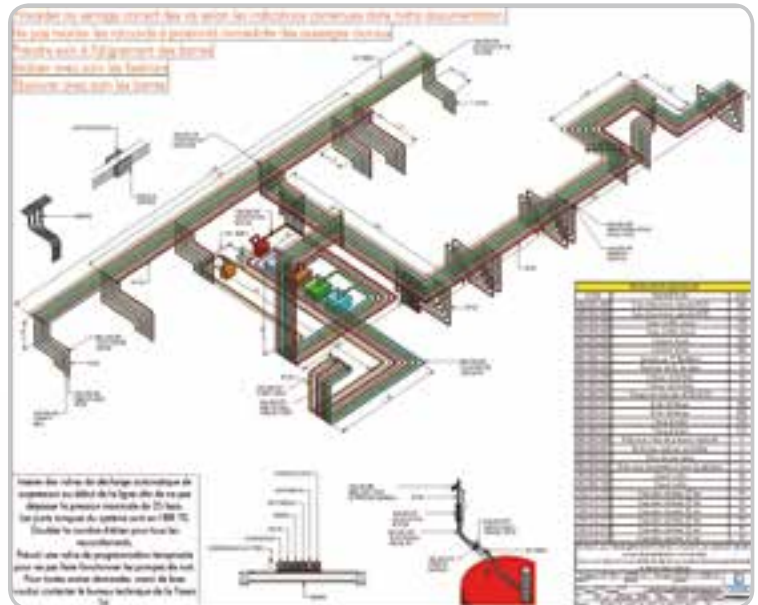

ITALIAN DESIGN AS A VALUE

At Teseo we design and project using the most modern three-dimensional CAD system combined with flexible and expedient methods.

We face each project searching for innovation, considering the environmental and ergonomic impacts. Moreover, we try to make the most of the DESIGN, by optimizing the production process and by assuring quality and functionality.

We co-operate with external offices, with university departments but most of all with our customers. They help us and drive our innovation by discussing their necessities and experiences.

Each patent requires a lot of technical work, for the carrying out of the technical patented drawings, for the evaluation of the precedence, for the compilation of our technical requests from the reference institute, and afterwards for the maintenance and the legal protection of our rights and our customers.

The Certification and the homologation of our products are essential for us, the engagement in collaborating with certification institutes is constant as we prefer, even if we are sure about quality and safety of our production, to get approvals in a serious and open way. Teseo designs according to the standards UNI ISO for planning as UNI 4820, UNI 5456 and others.

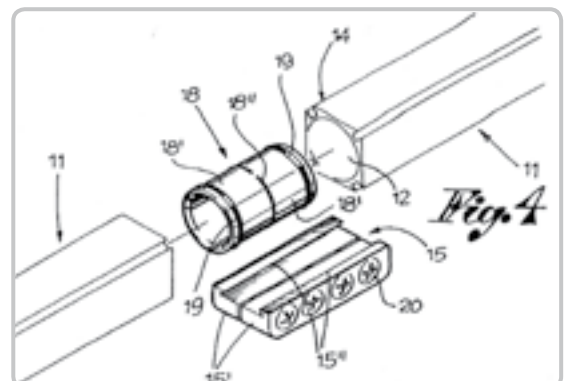
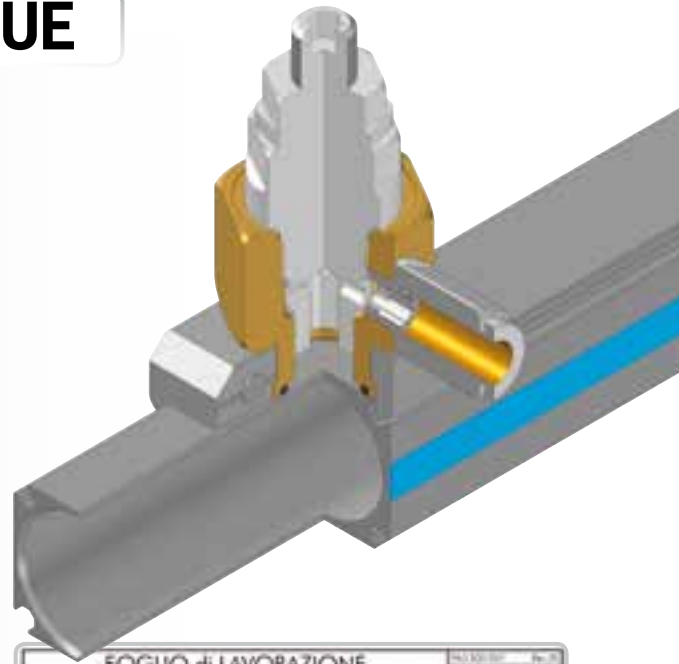

PATENTS

A patent is at the origin of Teseo design philosophy and we are constantly searching for new patented solutions.

Our patents are issued to protect the creativeness of our technical staff and the reliance of our distribution network together with all our customers who are looking for innovation and quality of the products purchased.

At Teseo we consider that the patents are vitally important, and are the only distinguishing marks of the innovative inventors and manufacturers.

Today our R & D Technical office, are managing various patents registered in different countries and developing new patented products also for Design. To make our philosophy more clearly identified and original, Teseo has registered its own trade mark Worldwide.



CERTIFICATION

The Design, production and Quality management is certified according to the standard UNI EN ISO 9001. SGS, the most famous certification institute, analyses and approves our management system, with an annual audit for the checking of the level and its improvement.

Teseo components are tested in our internal test department and also through external certified structures SIT, ISPEL, UNI or institutes such as SGS, TUV, TSSA and others.

Our quality management department collaborates with external qualified and experienced consultants in our industrial field.

Teseo components are manufactured with quality raw materials according to standard ISO: UNI EN 755-2, UNI EN 755-3, UNI EN 515, UNI EN 573-3, UNI EN 1706, UNI 5931, UNI EN 1461, UNI EN 3601 and others.

Teseo components are tested according to various procedures; The TUV institute checked an assembly of the HBS, testing it to cyclical pressurization; The AQM society tested the principal components of the AP range up to 120 bars with a range of temperature from -20°C to +130°C; the SGS institute certified that the AP system succeeded with the failure test pressure at 160 bars.

The University of Torino independently tests and measures the flow rates of our piping while the Brescia university is co-operating with specific technical consultants.

The calibration tools used in Teseo are regularly tested and certified by MG.

Teseo pipework systems are in compliance with the US standards ANSI B31.3 and B31.9. Approved by the Certification Bodies of the different provinces of Canada

Teseo pipework systems are designed, manufactured and tested according to the safety requirements of the European Standard 2014/68/UE (PED).

Kiwa has determined that the quality management system of Teseo Srl meets the requirements of Annex III, E1 of the Pressure Equipment Directive 2014/68/UE.

Classification of reaction to fire in accordance with EN 13501-1:2007 +A1 2009.

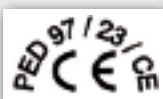

QUALITY

Teseo carries out inspection of all aspects of production to guarantee the suitability of its products. All parts are checked, not only at the manufacturing process but also during all the different assembly processes.

Each item is clearly identified by a product sheet with all the checks to be done according to the critical features of the products and its sizing using a plan sampling according to the standard UNI ISO 2859 that enables us to define a LQA chosen through 1.5, 2.5 and 6.5.



We carry out the quality check of the material by using the sampling frame in accordance with UNI ISO 2859. For each drawing there is a specific check sheet.

In each item sheet there is a list with the checks to be done, according to the criticality of the dimension we settle check coefficient "LQA" (acceptable quality limit). To be chosen among 1.5, 2.5 and 6.5.



Teseo's pipework system undergoes 10 functional, dimensional and aesthetical checks during all the production and packaging processes.

Teseo works with a product traceability process, where specified. This procedure allows Teseo to verify all the documentation in case of a non conformity and to point out the possible faults in the production process. Such procedure enables us to follow up the quality of our products with suppliers.

Further, we have planned preventive checks and settings of our measurement instruments. Written procedures were defined in order to regulate the setting's modalities and their frequency. Such procedures have been set for all those instruments and devices which can affect the safety and the quality of our production.



100% MADE IN ITALY

Teseo co-operates with the main Italian societies, always dedicated in any situation, to the highest levels of quality standards to get the best quality product in each step of its manufacturing process.

Teseo provides to the selection and the follow-up of each supplier based upon the certifications of the manufacturers, a study about relation price/quality, the importance of the supplier on the market, the control declaration sheet about the product, the availability and the modularity, the availability to supply in emergency conditions.

The calibrated pipework is extruded by highly efficient Italian extrusion companies. During the past years, they have succeeded in granting high precision production levels reducing non conformity reports close to zero.

Furthermore, Teseo have succeeded in strengthening business relations with the most Technically advanced manufacturing factories in Italy, they have invested in purchasing machine tools which are in the forefront to manufacture components increasing quality and reliability.

Teseo has a production department for the assembly of the components, where highly qualified staff is used to deal with several components, and are constantly up-dated on a technical and quality basis.

This department is managed according to the same quality management system Teseo uses for all our external suppliers.



HBS HOLLOW BAR SYSTEM

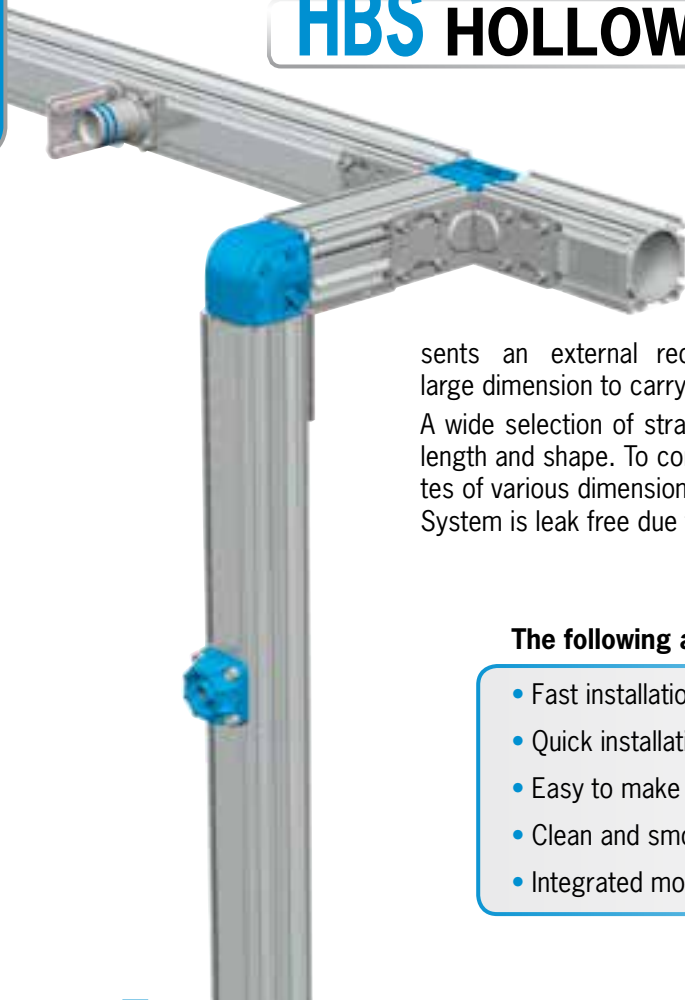

The great innovation of this unique system lies in the methods and means to add lines of compressed air and other fluids under pressure. The system is mainly composed of an extruded aluminium bar, which presents an external rectangular section with tee slots and an internal bore of large dimension to carry a considerable flow of compressed air.

A wide selection of straight joints, T or L joints allows for airlines of whatever length and shape. To complete the equipment we supply a number of outlet plates of various dimensions and shapes. The Teseo Modular aluminium Pipework System is leak free due to positive o-ring seals.

The following advantages stand out:

- Fast installation.
- Quick installation of additional outlets.
- Easy to make changes and add new branch lines.
- Clean and smooth inner and outer surfaces.
- Integrated modular system

EASY TO ASSEMBLE

DEBURRING



MOUNTING



ASSEMBLING



TIGHTENING



BLUE DESIGN

The new generation of the blue in **TESEO** is the result of the modification and the improvement of all the TESEO systems.

Our continuous R & D into **Energy Saving** together with a high regard for the **Design** ruled our technical choices. We studied the internal passages and the thicknesses to increase the flow rates through our tubing.

Double seats for the O-rings and high quality NBR **Blue O-Rings**, manufactured for Teseo, are applied to all the connections for high quality sealing.

Ergonomics of the complete system has been improved thanks to optimization of the shapes and weights. Precision manufacturing carried out on many components improves the outer finishing and removes the die-casting defects.

Outlet plates have been re-designed with new moulds, to improve quality and accuracy.

The blocking parts have been analyzed and improved.

The implementation of accessories and components is continuous.

Teseo are sourcing **New certifications** and international compatibility.



Indicative diagram for the choice of the HBS diameter according to compressor installed max power.

| Compressor power kW | HBS | Indicative flow rate (L 30 m - 6 bar - Δp 3%) NI/min |
|---------------------|-----|--|
| 19 | 25 | 2.900 |
| 36 | 32 | 5.400 |
| 110 | 50 | 16.400 |
| 195 | 63 | 29.200 |
| 350 | 80 | 53.000 |
| 785 | 110 | 117.500 |



Indicative diagrams of compressed air flow rates and related pressure drops in a line 30 m long (20°C - 1013 mbar).

The data used has been provided by the UNIVERSITY OF TURIN. See online software (page 9)

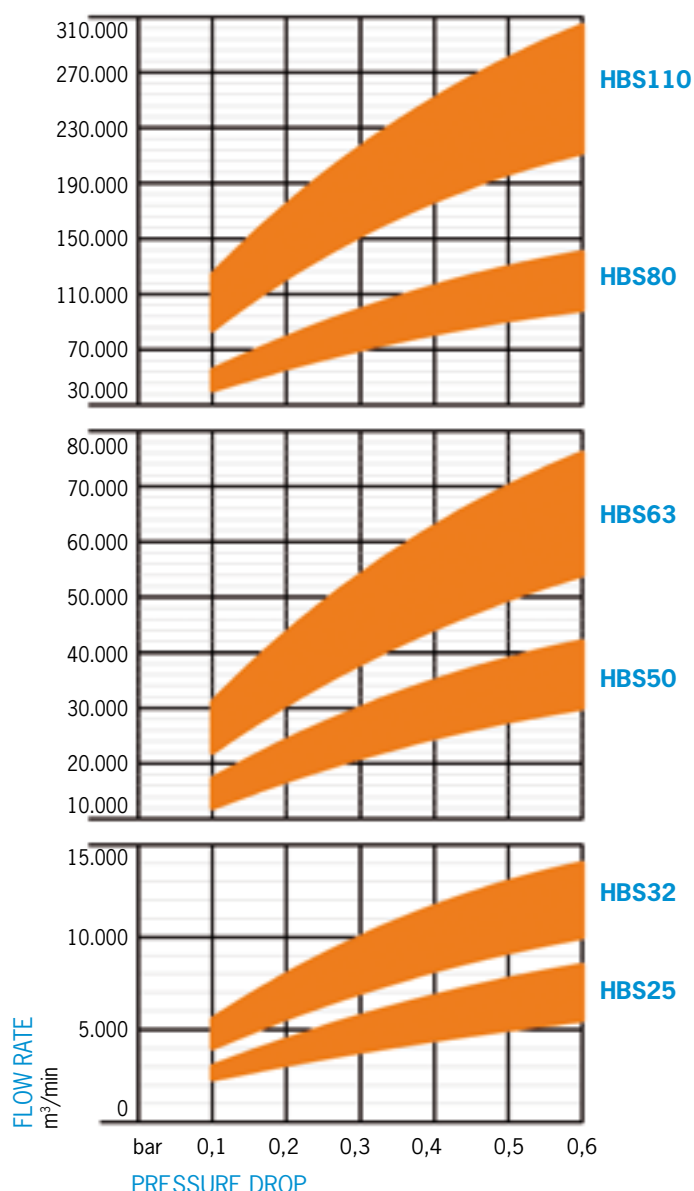

AIR PRESSURE: 6 → 12 bar
0,6 → 1,2 MPa
87 → 174 psi

TECHNICAL CHARACTERISTICS

| | |
|--|--|
| Extruded Aluminium | Alloy EN AW-6060 UNI EN 573-3:1996 |
| International designations | ANSI 6060 - DIN1748/1: AlMgSi 0,5 BS 6060 |
| Chemical composition | Si: 0,45% - Mg: 0,45% - Fe: 0,3% |
| Heat treatment | Aging T5 o T6 |
| Surface treatment (upon request) | Chemical silver anodization |
| Specific weight, density | Kg/dm³ 2,71 |
| Electrical conductivity | % IACS 53 |
| Thermal Conductivity | W/m·K 200 |
| Specific heat..... | J/Kg·K 96 |
| Coefficient of expansion..... | mm/m °C 0,024 |
| Tensile strength..... | Kg/mm² 24 |
| Yield strength..... | Kg/mm² 20 |
| Modulus of elasticity | Kg/mm² 6.700 |
| Brinell hardness | HB 70÷80 |
| Melting range..... | °C 600-650 |
| O-ring material | NBR 70 |
| Operating temperature..... | °C -20/+120 |
| Screw material | Steel class 8.8 |
| Screw driving torque | Nm 10÷13,5 (90÷120 Inch Lbs) |
| Outlet thread | BSP or NPT |
| Terminal thread | BSP or NPT |
| Max operating pressure | 15 bar - 1,5 MPa - 217 psi |
| Failure test pressure | 56 bar - 5,6 MPa - 813 psi |

Compatibility with fluids

Compressed air, Vacuum, Argon, Nitrogen, Carbon dioxide, Mineral oil*, Synthetic oil*, Other fluids*.

WARNING!

Teseo components are intended only to uses for which they have been specifically designed by the manufacturer and patent holder. This does not absolve the professional user to refrain from checking technical compatibility and current project of your application. Our technical department is at your disposal for evaluations, analysis of special use, to design and eventually implement specific components and assemblies. Teseo company is not responsible for any damage caused by improper, erroneous, unreasonable and product incompatibilities with applications not specified by the catalog.

*For further information, please apply to Teseo Srl Technical Office.

PROFILES SECTION OVER VIEW

HBS25

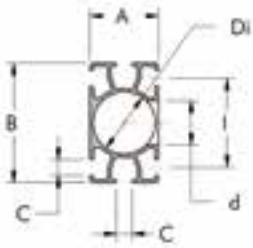

HBS32

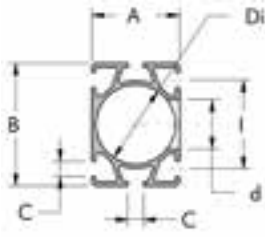

HBS50

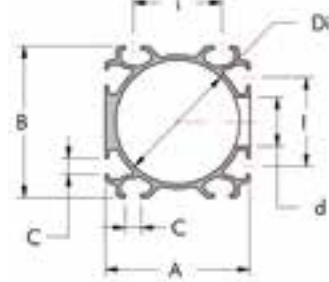

HBS110

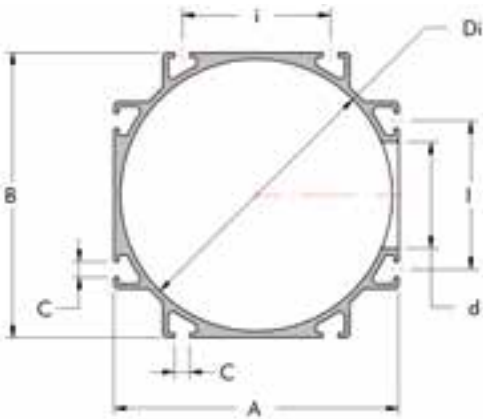

HBS80

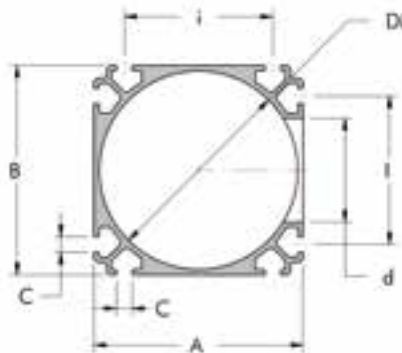

HBS63

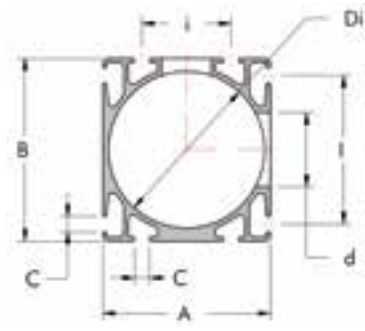

SIZE DIMENSIONS

| Name | Dimensions | | | | | | | Max hole | Inner volume | Weight | Moment of inertia | | Section area |
|--------|------------|------|------|------|------|------|-------|----------|--------------|--------|--------------------|--------------------|--------------|
| | Di mm | A mm | B mm | l mm | i mm | C mm | d mm | | | | Jx cm ⁴ | Jy cm ⁴ | |
| HBS25 | 25 | 28 | 49 | 36 | - | 6,2 | 18 | 0,5 | 800 | 6,70 | 2,90 | 5 | |
| HBS32 | 32 | 36 | 50 | 36 | - | 6,2 | 20 | 0,8 | 1150 | 11,90 | 6,60 | 8 | |
| HBS50 | 50 | 60 | 60 | 36 | 36 | 6,2 | 20 | 2,0 | 1800 | 25,00 | 31,50 | 20 | |
| HBS63 | 63 | 68 | 74 | 60 | 36 | 6,2 | 20/30 | 3,1 | 2770 | 74,20 | 58,80 | 31 | |
| HBS80 | 80 | 85 | 85 | 60 | 60 | 6,2 | 42 | 5,0 | 3300 | 120,00 | 120,00 | 50 | |
| HBS110 | 110 | 115 | 115 | 60 | 60 | 6,2 | 43 | 9,5 | 4200 | 265,00 | 265,00 | 95 | |

NATURAL ALUMINIUM EXTRUDED PIPE

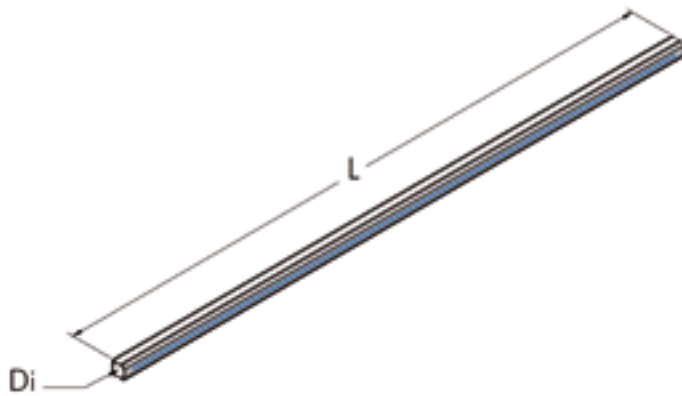

| Di mm | L m | Part. no. | P Kg | n° | |
|----------|--------|--------------|---------|----|--|
| 25 | 5 | 800 028 500 | 4,0 | 32 | |
| 32 | 5 | 800 036 500 | 5,7 | 24 | |
| 50 | 5 | 800 060 500 | 9,0 | 16 | |
| 63 | 5 | 800 068 500 | 13,8 | 12 | |
| 80 | 5 | 800 085 500 | 16,7 | 8 | |
| 110 | 5 | 800 114 500 | 21,0 | 4 | |

| Di mm | L m | Part. no. | P Kg | n° | |
|----------|--------|--------------|---------|----|--|
| 25 | 2,5 | 800 028 250 | 2,0 | 32 | |
| 32 | 2,5 | 800 036 250 | 2,9 | 24 | |
| 50 | 2,5 | 800 060 250 | 4,5 | 16 | |
| 63 | 2,5 | 800 068 250 | 6,9 | 12 | |
| 80 | 2,5 | 800 085 250 | 8,3 | 8 | |
| 110 | 2,5 | 800 114 250 | 10,5 | 4 | |

ANODIZED ALUMINIUM EXTRUDED PIPE

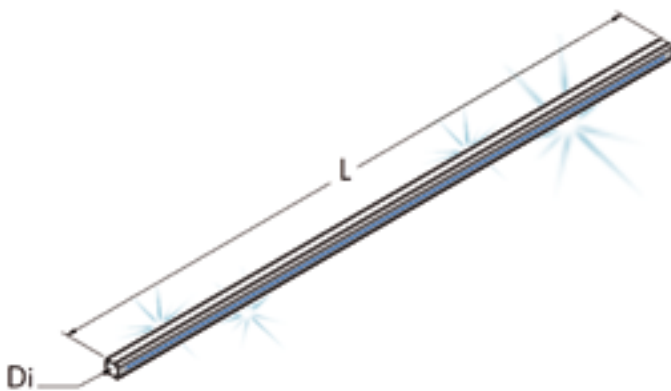

| Di mm | L m | Part. no. | P Kg | n° | |
|----------|--------|--------------|---------|----|--|
| 25 | 5 | 801 028 500 | 4,0 | 32 | |
| 32 | 5 | 801 036 500 | 6,3 | 24 | |
| 50 | 5 | 801 060 500 | 9,5 | 16 | |
| 63 | 5 | 801 068 500 | 14,0 | 12 | |
| 80 | 5 | 801 085 500 | 17,0 | 8 | |
| 110 | 5 | 801 114 500 | 21,3 | 4 | |

| Di mm | L m | Part. no. | P Kg | n° | |
|----------|--------|--------------|---------|----|--|
| 25 | 2,5 | 801 028 250 | 2,0 | 32 | |
| 32 | 2,5 | 801 036 250 | 3,1 | 24 | |
| 50 | 2,5 | 801 060 250 | 4,7 | 16 | |
| 63 | 2,5 | 801 068 250 | 7,0 | 12 | |
| 80 | 2,5 | 801 085 250 | 8,5 | 8 | |
| 110 | 2,5 | 801 114 250 | 10,6 | 4 | |

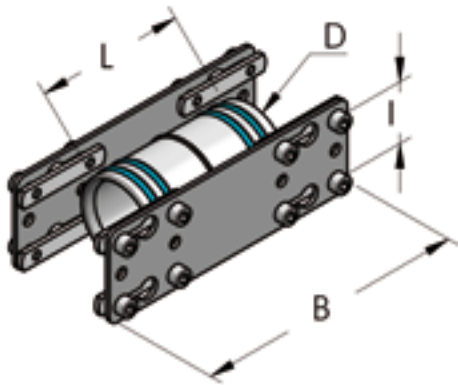
STRAIGHT JOINT, COMPLETE

| D mm | I mm | L mm | B mm | Part. no. | P g |  n° |
|---------|---------|---------|---------|--------------|--------|---|
| 25* | 36 | 50 | 120 | 003 000 020 | 180 | 20 |
| 32* | 36 | 65 | 120 | 003 001 020 | 200 | 20 |
| 50 | 36 | 90 | 160 | 003 002 020 | 570 | 10 |
| 63 | 36-60 | 106 | 160 | 003 003 020 | 770 | 10 |
| 80 | 60 | 130 | 160 | 003 004 020 | 950 | 10 |
| 110 | 60 | 180 | 230 | 003 005 020 | 2000 | 5 |

* It is suggested to the user, if the application makes it necessary, the implementation with the components:

711 048 120 + 725 010 056 + 212 006 008 (Page 32 and 34)

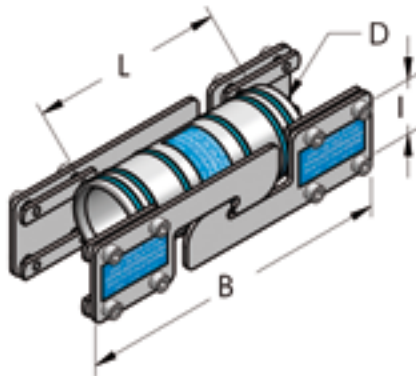
SLIDING JOINT, COMPLETE

| D mm | I mm | L mm | B mm | Part. no. | P g |  n° |
|---------|---------|---------|---------|--------------|--------|--|
| 25 | 36 | 75 | 200 | 003 000 021 | 420 | 10 |
| 32 | 36 | 95 | 200 | 003 001 021 | 450 | 10 |
| 50 | 36 | 130 | 200 | 003 002 021 | 780 | 10 |
| 63 | 60 | 150 | 200 | 003 003 021 | 1000 | 5 |
| 80 | 60 | 180 | 200 | 003 004 021 | 1400 | 5 |
| 110 | 60 | 280 | 280 | 003 005 021 | 2500 | 5 |

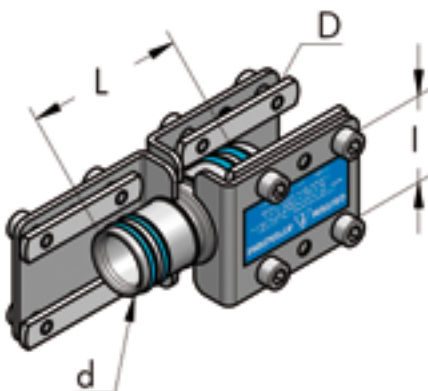
REDUCTION STRAIGHT JOINT, COMPLETE

| D mm | d mm | L mm | I mm | Part. no. | P g |  n° |
|---------|---------|---------|---------|--------------|--------|---|
| 32 | 25 | 66 | 36 | 003 001 049 | 270 | 10 |
| 50 | 32 | 88 | 36 | 003 002 049 | 621 | 10 |
| 63 | 50 | 105 | 36 | 003 003 049 | 777 | 5 |
| 80 | 63 | 125 | 60 | 003 004 049 | 1470 | 5 |
| 110 | 80 | 280 | 60 | 003 005 049 | 3000 | 2 |

L JOINT, COMPLETE

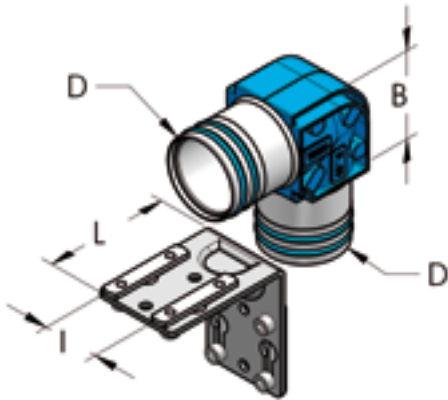

| D mm | I mm | L mm | B mm | Part. no. | P g | n° | |
|---------|---------|---------|---------|--------------|--------|----|--|
| 25 | 36 | 60 | 30 | 003 000 022 | 240 | 20 | |
| 32 | 36 | 60 | 42 | 003 001 022 | 280 | 20 | |
| 50 | 36 | 80 | 60 | 003 002 022 | 530 | 10 | |
| 63 | 36-60 | 80 | 75 | 003 003 022 | 1400 | 10 | |
| 80 | 60 | 80 | 85 | 003 004 022 | 2600 | 10 | |
| 110 | 60 | 110 | 165 | 003 005 022 | 3000 | 5 | |

T JOINT, COMPLETE

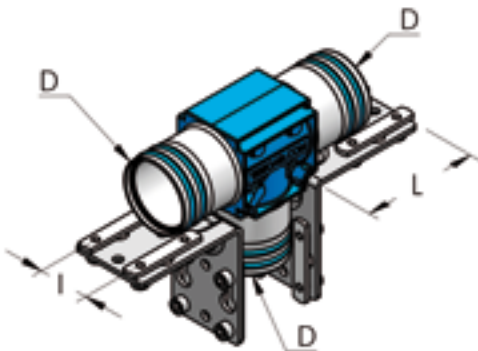



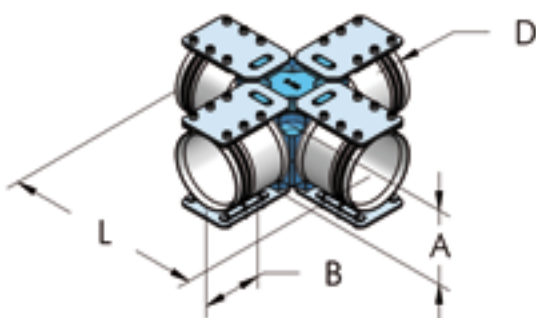

| D mm | I mm | L mm | B mm | Part. no. | P g | n° | |
|---------|---------|---------|---------|--------------|--------|----|--|
| 25 | 36 | 60 | 30 | 003 000 024 | 400 | 10 | |
| 32 | 36 | 60 | 50 | 003 001 024 | 430 | 10 | |
| 50 | 36 | 80 | 60 | 003 002 024 | 820 | 10 | |
| 63 | 36-60 | 80 | 75 | 003 003 024 | 2100 | 10 | |
| 80 | 60 | 80 | 85 | 003 004 024 | 3500 | 5 | |
| 110/80 | 60 | 110 | 230 | 003 005 023 | 3900 | 2 | |
| 110 | 60 | 110 | 230 | 003 005 024 | 4000 | 2 | |

CROSS JOINT, COMPLETE

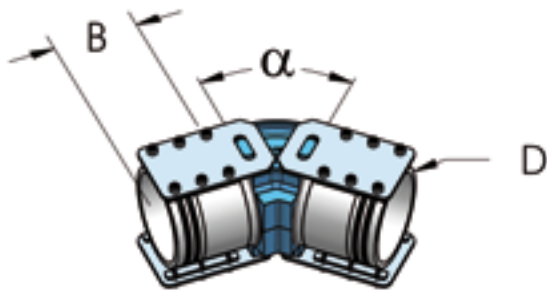

| D mm | L mm | A mm | B mm | Part. no. | P kg | n° | |
|---------|---------|---------|---------|--------------|---------|----|--|
| 80 | 260 | 83 | 60 | 003 004 045 | 4,6 | 2 | |
| 110 | 306 | 114 | 90 | 003 005 045 | 5,6 | 2 | |

45° JOINT, COMPLETE

| D mm | α ° | B mm | Part. no. | P kg |  | n° |
|---------|---------------|---------|--------------|---------|---|---|
| 80 | 45 | 60 | 003 004 051 | 2,4 | | 2  |
| 110 | 45 | 90 | 003 005 051 | 3,2 | | 2  |

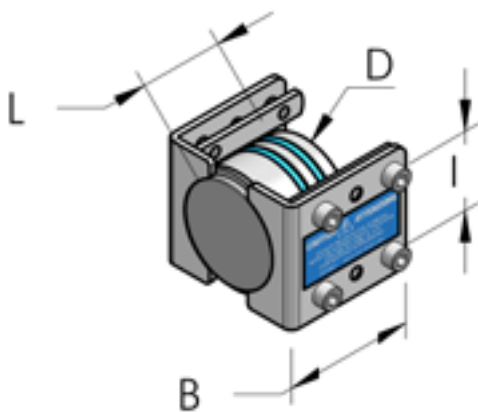
CLOSED TERMINAL, COMPLETE

| D mm | I mm | L mm | B mm | Part. no. | P g |  | n° |
|---------|---------|---------|---------|--------------|--------|--|----|
| 25 | 36 | 29 | 60 | 003 000 026 | 120 | | 20 |
| 32 | 36 | 32 | 60 | 003 001 026 | 120 | | 20 |
| 50 | 36 | 40 | 60 | 003 002 026 | 430 | | 10 |
| 63 | 60 | 40 | 60 | 003 003 026 | 700 | | 10 |
| 80 | 60 | 66 | 80 | 003 004 026 | 1350 | | 5 |
| 110 | 60 | 150 | 110 | 003 005 026 | 2000 | | 2 |

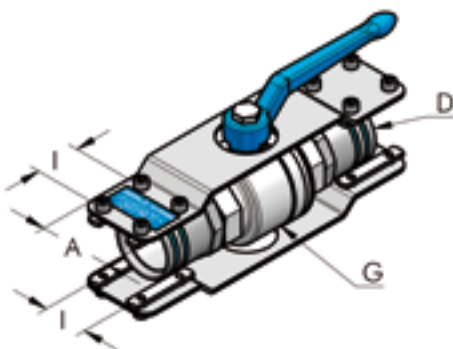
BALL VALVE, COMPLETE

| D mm | G | I mm | A mm | Part. no. | P g |  | n° |
|---------|--------------|---------|---------|--------------|--------|---|----|
| 25 | 3/4" - BSP | 36 | 50 | 003 000 046 | 630 | | 10 |
| 32 | 1" - BSP | 36 | 50 | 003 001 046 | 1120 | | 10 |
| 50 | 1 1/2" - BSP | 36 | 60 | 003 002 046 | 2050 | | 10 |
| 63 | 2" - BSP | 36 | 60 | 003 003 046 | 3360 | | 10 |
| 80 | 2 1/2" - BSP | 60 | 72 | 003 004 046 | 5300 | | 5 |
| 110 | 4" - BSP | 60 | 78 | 003 005 046 | 12600 | | 2 |

KIT FOR BALL VALVE

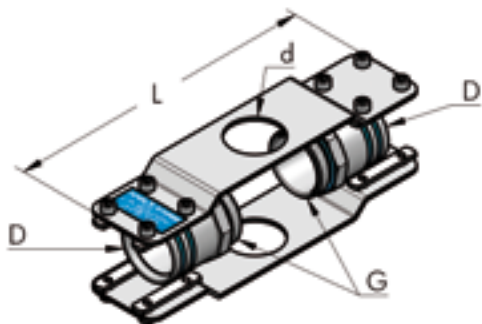

| D mm | G | L mm | d mm | Part. no. | P g | n° |
|---------|--------------|---------|---------|--------------|--------|----|
| 25 | 3/4" - BSP | 220 | 30 | 003 000 047 | 340 | 10 |
| 32 | 1" - BSP | 220 | 30 | 003 001 047 | 650 | 10 |
| 50 | 1 1/2" - BSP | 250 | 42 | 003 002 047 | 740 | 10 |
| 63 | 2" - BSP | 250 | 42 | 003 003 047 | 910 | 10 |
| 80 | 2 1/2" - BSP | - | - | 003 004 047 | 1400 | 5 |

TERMINAL WITH THREADED HOLE, COMPLETE

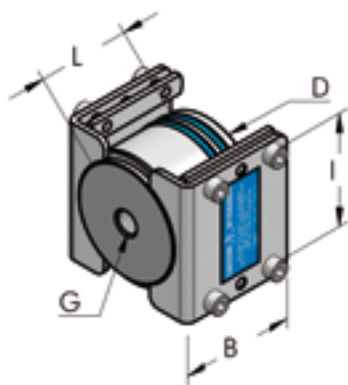

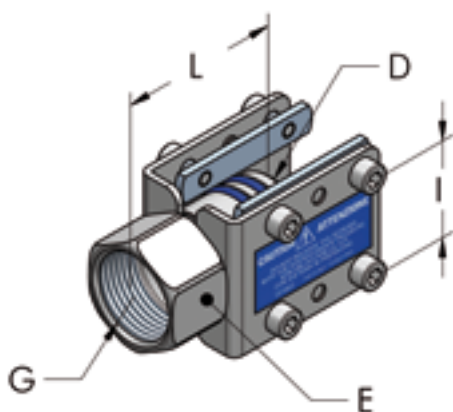

| D mm | G | L mm | B mm | I mm | Part. no. | P g | n° |
|---------|------------|---------|---------|---------|--------------|--------|----|
| 25 | 1/4" - BSP | 28 | 60 | 36 | 003 000 025 | 114 | 20 |
| 32 | 1/4" - BSP | 32 | 60 | 36 | 003 001 025 | 130 | 20 |
| 32 | 1/2" - BSP | 32 | 60 | 36 | 003 001 031 | 128 | 20 |
| 50 | 1/4" - BSP | 40 | 60 | 36 | 003 002 025 | 440 | 20 |
| 50 | 1/2" - BSP | 50 | 60 | 36 | 003 002 029 | 430 | 20 |
| 63 | 1/4" - BSP | 50 | 60 | 60 | 003 003 025 | 656 | 20 |
| 80 | 1/4" - BSP | 66 | 80 | 60 | 003 004 025 | 1300 | 20 |
| 80 | 1/2" - BSP | 66 | 80 | 60 | 003 004 029 | 1300 | 20 |
| 110 | 3/8" - BSP | 150 | 110 | 60 | 003 005 025 | 2000 | 2 |

TERMINAL THREADED FEMALE, COMPLETE

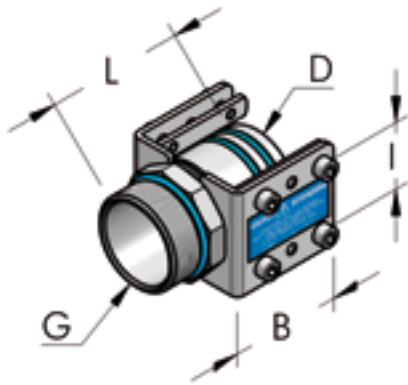

| D mm | G | E mm | L mm | I mm | Part. no. | P g | n° |
|---------|--------------|---------|---------|---------|--------------|--------|----|
| 25 | 3/4" - BSP | 30 | 45 | 36 | 003 000 027 | 120 | 20 |
| 32 | 1" - BSP | 36 | 60 | 36 | 003 001 027 | 140 | 20 |
| 50 | 1 1/2" - BSP | 52 | 70 | 36 | 003 002 028 | 340 | 20 |
| 63 | 1 1/2" - BSP | 65 | 72 | 60 | 003 003 028 | 440 | 10 |
| 80 | 1" - BSP | - | 66 | 60 | 003 004 027 | 1300 | 20 |
| 80 | 2" - BSP | 82 | 95 | 60 | 003 004 028 | 920 | 10 |
| 110 | 2 1/2" - BSP | 115 | 150 | 60 | 003 005 028 | 2000 | 2 |



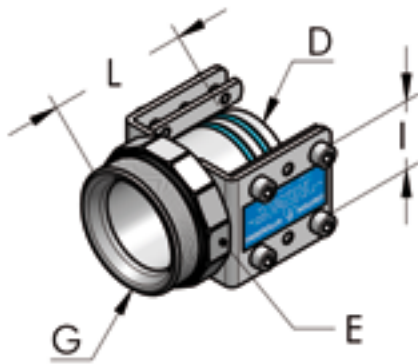

NIPPLE THREADED MALE, COMPLETE

| D mm | G | L mm | B mm | I mm | Part. no. | P g |  n° |
|---------|--------------|---------|---------|---------|--------------|--------|---|
| 25 | 3/4" - BSP | 47 | 60 | 36 | 003 000 029 | 110 | 20 |
| 32 | 1" - BSP | 55 | 60 | 36 | 003 001 030 | 230 | 20 |
| 50 | 1 1/2" - BSP | 76 | 60 | 36 | 003 002 030 | 330 | 20 |
| 63 | 2" - BSP | 80 | 60 | 60 | 003 003 030 | 430 | 10 |
| 80 | 2 1/2" - BSP | 100 | 80 | 60 | 003 004 030 | 650 | 10 |

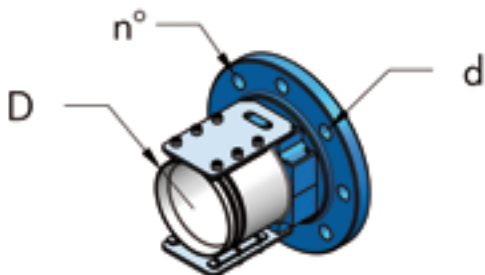
TERMINAL THREADED MALE, COMPLETE

| D mm | G | L mm | E mm | I mm | Part. no. | P g |  n° |
|---------|--------------|---------|---------|---------|--------------|--------|---|
| 25 | 1" - BSP | 45 | 36 | 36 | 003 000 030 | 130 | 20 |
| 32 | 1 1/4" - BSP | 61 | 50 | 36 | 003 001 029 | 190 | 20 |
| 50 | 2" - BSP | 75 | 65 | 36 | 003 002 031 | 440 | 20 |
| 63 | 2 1/2" - BSP | 90 | 82 | 60 | 003 003 031 | 600 | 10 |
| 80 | 3" - BSP | 110 | 90 | 60 | 003 004 031 | 830 | 10 |
| 110 | 4" - BSP | 152 | 115 | 60 | 003 005 031 | 1500 | 5 |

FLANGED ADAPTER

| D mm | d mm | Norm | n° | Part. no. | P kg |  n° |
|---------|---------|-------------|----|--------------|---------|---|
| 80 | 18 | UNI-EN 1092 | 4 | 003 004 050 | 2,4 | 2  |
| 80 | 19 | ASME 150lb | 4 | 003 004 450 | 1,6 | 2  |
| 110 | 18 | UNI-EN 1092 | 8 | 003 005 050 | 3,3 | 2  |
| 110 | 19 | ASME 150lb | 8 | 003 005 450 | 3,4 | 2  |

I36 FEMALE OUTLET PLATE, COMPLETE

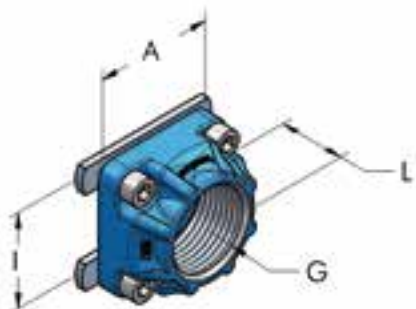

| I mm | G | A mm | L mm | Part. no. | P g | n° | |
|---------|------------|---------|---------|--------------|--------|----|--|
| 36 | 1/8" - BSP | 50 | 25 | 003 001 032 | 80 | 20 | |
| 36 | 1/4" - BSP | 50 | 25 | 003 001 033 | 80 | 20 | |
| 36 | 3/8" - BSP | 50 | 25 | 003 001 034 | 80 | 20 | |
| 36 | 1/2" - BSP | 50 | 25 | 003 002 033 | 110 | 20 | |
| 36 | 3/4" - BSP | 50 | 25 | 003 002 034 | 105 | 20 | |
| 36 | 1" - BSP | 50 | 25 | 003 002 035 | 90 | 20 | |

I60 FEMALE OUTLET PLATE, COMPLETE

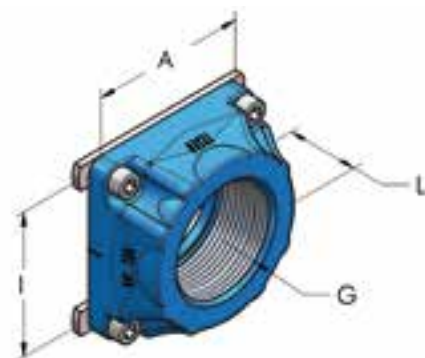

| I mm | G | A mm | L mm | Part. no. | P g | n° | |
|---------|--------------|---------|---------|--------------|--------|----|--|
| 60 | 1/2" - BSP | 72 | 30 | 003 003 033 | 250 | 10 | |
| 60 | 3/4" - BSP | 72 | 30 | 003 003 034 | 220 | 20 | |
| 60 | 1" - BSP | 72 | 30 | 003 003 035 | 200 | 10 | |
| 60 | 1 1/4" - BSP | 72 | 30 | 003 003 038 | 175 | 10 | |
| 60 | 1 1/2" - BSP | 72 | 30 | 003 003 036 | 150 | 10 | |
| 60 | 2" - BSP | 72 | 30 | 003 003 039 | 193 | 10 | |

MODULAR OUTLET PLATE

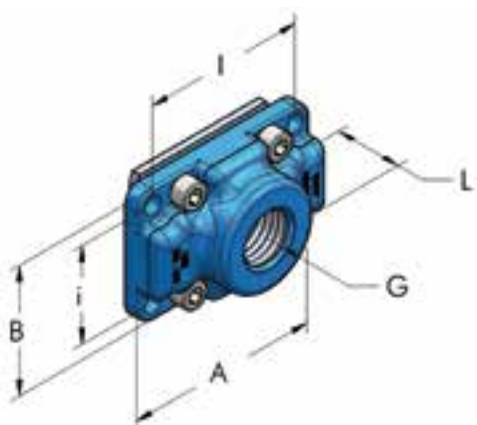





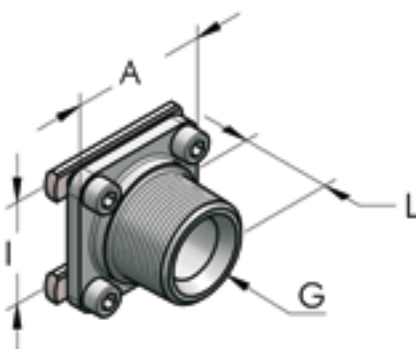

| I mm | i mm | G | A mm | B mm | L mm | Part. no. | P g | n° | |
|---------|---------|------------|---------|---------|---------|--------------|--------|----|--|
| 60 | 36 | 1/8" - BSP | 72 | 48 | 25 | 003 360 030 | 140 | 10 | |
| 60 | 36 | 1/4" - BSP | 72 | 48 | 25 | 003 360 031 | 137 | 10 | |
| 60 | 36 | 3/8" - BSP | 72 | 48 | 25 | 003 360 032 | 133 | 10 | |
| 60 | 36 | 1/2" - BSP | 72 | 48 | 25 | 003 360 033 | 129 | 10 | |
| 60 | 36 | 3/4" - BSP | 72 | 48 | 25 | 003 360 034 | 125 | 10 | |
| 60 | 36 | 1" - BSP | 72 | 48 | 25 | 003 360 035 | 120 | 10 | |

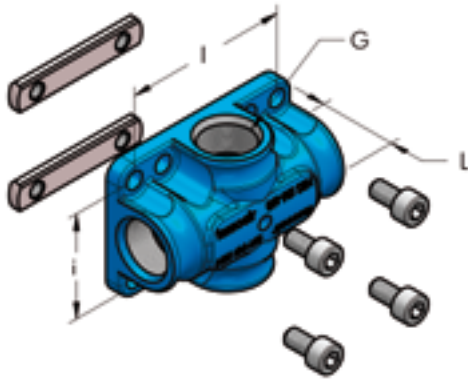
MALE OUTLET PLATE, COMPLETE







| I mm | G | A mm | L mm | Part. no. | P g | n° | |
|---------|----------|---------|---------|--------------|--------|----|--|
| 36 | 1" - BSP | 48 | 32 | 003 002 036 | 120 | 20 | |
| 60 | 2" - BSP | 70 | 49 | 003 004 036 | 600 | 10 | |

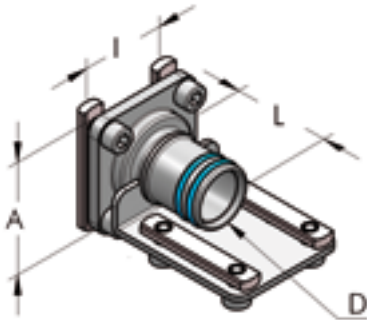

FEMALE MULTIPLE OUTLET PLATE, COMPLETE

| I mm | i mm | Holes | G | L mm | Part. no. | P g |  | n° |
|---------|---------|-------|------------|---------|--------------|--------|---|----|
| 60 | 36 | 4 | 1/4" - BSP | 30 | 003 360 054 | 190 |  | 10 |
| 60 | 36 | 4 | 3/8" - BSP | 30 | 003 360 056 | 175 |  | 10 |
| 60 | 36 | 4 | 1/2" - BSP | 30 | 003 360 058 | 150 |  | 10 |
| 60 | 36 | 2 | 1/2" - BSP | 30 | 003 360 059 | 160 |  | 10 |

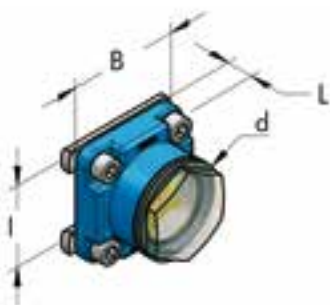

REDUCTION PLATE, COMPLETE

| D mm | I mm | A mm | L mm | Part. no. | P g |  | n° |
|---------|---------|---------|---------|--------------|--------|---|----|
| 25 | 36 | 48 | 40 | 003 000 037 | 190 |  | 20 |
| 32 | 36 | 48 | 44 | 003 002 037 | 200 |  | 20 |
| 50 | 60 | 70 | 60 | 003 003 037 | 530 |  | 10 |
| 63 | 60 | 70 | 72 | 003 004 037 | 610 |  | 10 |

CONDENSATE LEVEL SPY HOLE

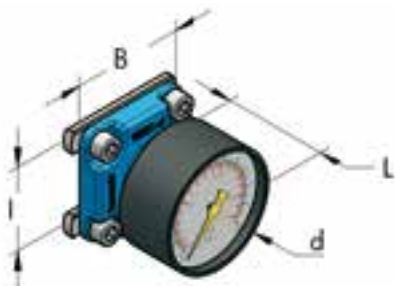
| I mm | d mm | L mm | B mm | Part. no. | P g |  | n° |
|---------|---------|---------|---------|--------------|--------|---|----|
| 36 | 40 | 10 | 48 | 003 001 044 | 100 |  | 20 |
| 60 | 40 | 12 | 72 | 003 003 044 | 180 |  | 10 |

MANOMETER, COMPLETE

| I mm | d mm | L mm | B mm | Part. no. | P g |  | n° |
|---------|---------|---------|---------|--------------|--------|---|----|
| 36 | 50 | 45 | 48 | 003 001 048 | 144 |  | 10 |
| 60 | 50 | 55 | 72 | 003 003 048 | 205 |  | 10 |

FLEXIBLE PIPE FOR CONNECTION TO COMPRESSOR

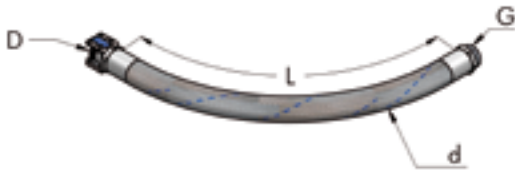

| D mm | G | L mm | d mm | Part. no. | P g | n° | |
|---------|--------------|---------|---------|--------------|--------|----|--|
| 25 | 1" - BSP | 1000 | 37 | 003 000 058 | 1700 | 20 | |
| 32 | 1 1/4" - BSP | 1000 | 44 | 003 001 058 | 2200 | 20 | |
| 50 | 2" - BSP | 1000 | 65 | 003 002 058 | 4000 | 20 | |
| 63 | 2 1/2" - BSP | 1300 | 77 | 003 003 058 | 4700 | 20 | |
| 80 | 3" - BSP | 1600 | 90 | 003 004 058 | 5800 | 20 | |

FLEXIBLE JOINT FOR HBS-HBS CONNECTION



| D mm | d mm | I mm | L mm | Part. no. | P g | n° | |
|---------|---------|---------|---------|--------------|--------|----|--|
| 25 | 37 | 1000 | 1050 | 003 000 059 | 1900 | 10 | |
| 32 | 44 | 1000 | 1080 | 003 001 059 | 2400 | 10 | |
| 50 | 65 | 1000 | 1100 | 003 002 059 | 4300 | 10 | |
| 63 | 77 | 1300 | 1450 | 003 003 059 | 5000 | 10 | |
| 80 | 90 | 1600 | 1800 | 003 004 059 | 6300 | 10 | |

U BRACKET, COMPLETE

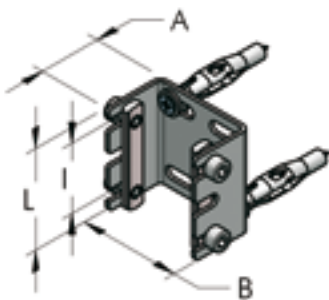

| I mm | B mm | L mm | A mm | Part. no. | P g | n° | |
|---------|---------|---------|---------|--------------|--------|----|--|
| 36 | 50 | 52 | 30 | 003 000 040 | 140 | 20 | |

For HBS 25 Only

L PLATE, COMPLETE

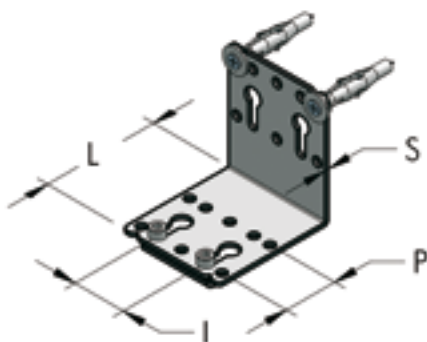

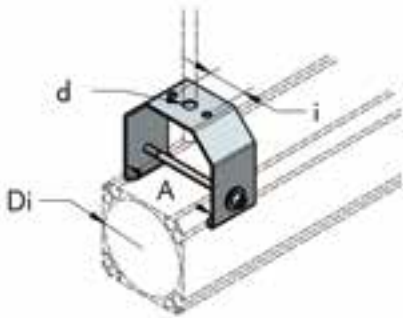

| I mm | P mm | L mm | S mm | Part. no. | P g | n° | |
|---------|---------|---------|---------|--------------|--------|----|--|
| 36 | 36 | 60 | 2 | 003 001 040 | 100 | 20 | |
| 36-60 | 36 | 80 | 3 | 003 003 040 | 260 | 20 | |
| 36-60 | 36-60 | 140 | 3,5 | 003 004 040 | 430 | 20 | |

HANGING BRACKET

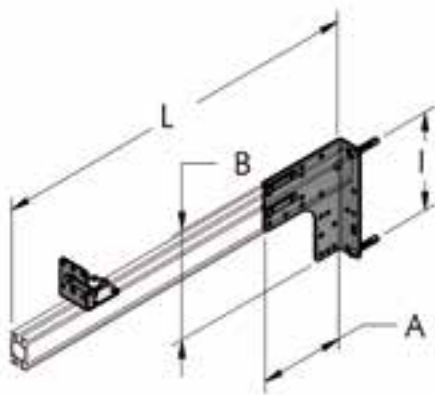
| Di mm | A mm | d mm | i mm | Part. no. | P g |  n° |
|----------|---------|---------|---------|--------------|--------|--|
| 50/63 | 68 | 11 | 36 | 003 003 073 | 395 | 10 |
| 80 | 85 | 11 | 36 | 003 004 073 | 391 | 10 |
| 110 | 115 | 11 | 36 | 003 005 073 | 481 | 10 |

SUPPORT BRACKET, COMPLETE

| A mm | B mm | I mm | L mm | Part. no. | P g |  n° |
|---------|---------|---------|---------|--------------|--------|--|
| 130 | 170 | 140 | 600 | 003 001 070 | 1300 | 10  |
| 130 | 170 | 140 | * | 003 001 071 | 360 | 10 |

*without bar

ADHESIVE COLOUR STICKERS

| L mm | Colour | Part. no. | P g |  n° |
|---------|-----------------|--------------|--------|--|
| 310 | Blue RAL 5015 | 104 025 150 | 29 | 11 |
| 310 | Brown RAL 8003 | 104 028 316 | 29 | 11 |
| 310 | Grey RAL 7000 | 104 028 317 | 29 | 11 |
| 310 | Red RAL 3020 | 104 028 318 | 29 | 11 |
| 310 | Yellow RAL 1028 | 104 028 319 | 29 | 11 |
| 310 | Green RAL 6029 | 104 028 315 | 29 | 11 |

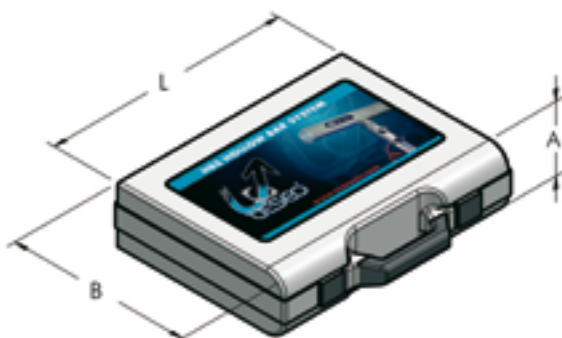
DEMO SUIT-CASE

| A mm | B mm | L mm | Configuration | Part. no. | P g |  n° |
|---------|---------|---------|---------------|--------------|--------|--|
| 130 | 380 | 490 | 22 HBS parts | 003 001 090 | 4500 | 1 |

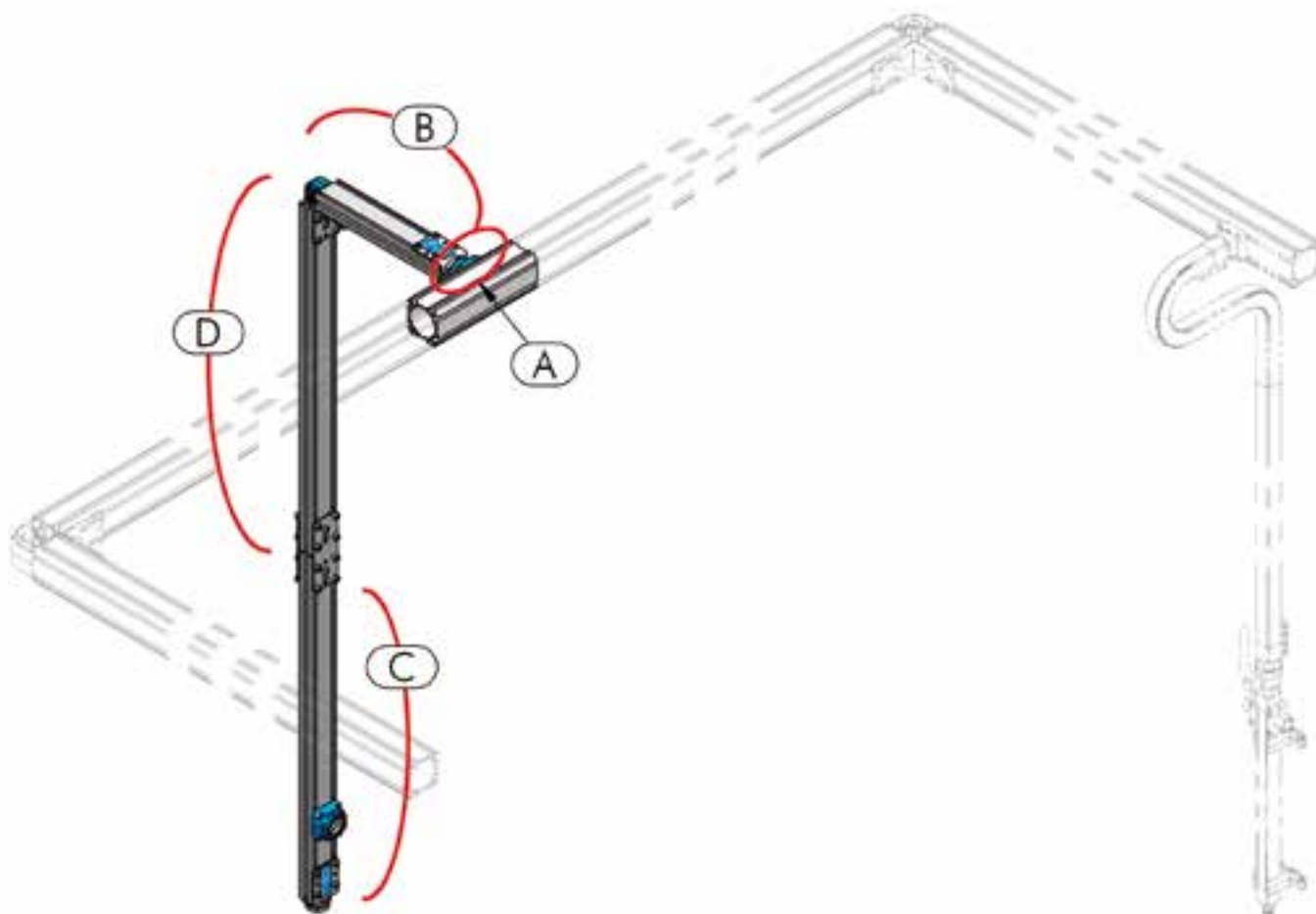





CREATE YOUR DROP COLUMN

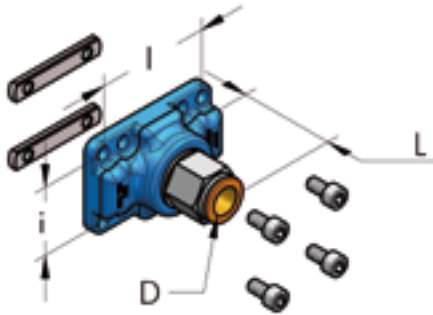

- A - Confirm the characteristics of your main line and of the secondary lines that derive from it, to define a components list.
- B - Study the route from the main line that the secondary lines have to take and choose the components and pipework needed.
- C - Define the types of end of line attachments required and choose the appropriate components.
- D - Verify the pipework's route from B to C and choose the quantity of pipework and the components needed

| | |
|---|--------------------------------------|
| A | HBS pages 24-25-26-27-31 |
| | AP page 53 |
| B | HBS pages 20-22-28 |
| | AP pages 44-45-49-55-56 |
| C | HBS pages 20-21-23-24-25-26-27-28-31 |
| | AP pages 45-46-47-49-50-55 |
| D | HBS pages 20-21-31 |
| | AP pages 44-45 |

REDUCTION PLATE FOR D14 COLUMN, COMPLETE

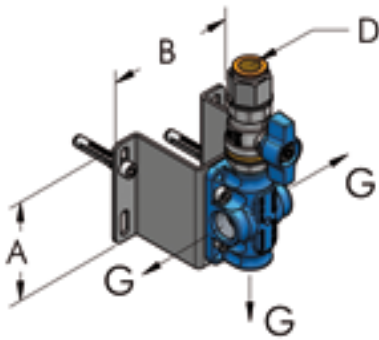
| I mm | i mm | D mm | L mm | Part. no. | P g |  | n° |
|---------|---------|---------|---------|--------------|--------|---|---|
| 36 | 36 | 14 | 50 | 003 001 134 | 160 | 20 |  |
| 60 | 60 | 14 | 55 | 003 003 134 | 300 | 20 |  |
| 60 | 36 | 14 | 55 | 003 360 134 | 170 | 20 |  |

3 OUTLETS BLOCK FOR D14 DROP COLUMN, COMPLETE

| D mm | G | A mm | B mm | Part. no. | P g |  | n° |
|---------|------------|---------|---------|--------------|--------|---|---|
| 14 | 3/8" - BSP | 75 | 95 | 003 001 068 | 700 | 20 |  |
| 14 | 1/2" - BSP | 75 | 95 | 003 002 068 | 750 | 20 |  |

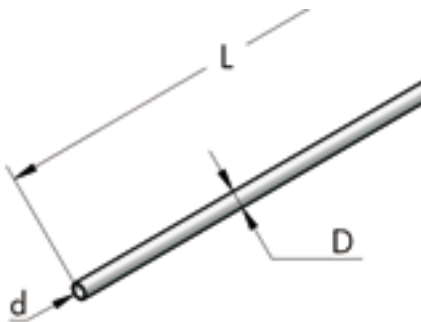
STRAIGHT PIPE FOR D14 DROP COLUMN

| D mm | d mm | L m | Part. no. | P g |  | n° |
|---------|---------|--------|--------------|--------|---|----|
| 14 | 12 | 1 | 425 014 100 | 106 | 20 | |
| 14 | 12 | 5 | 425 014 500 | 530 | 20 | |

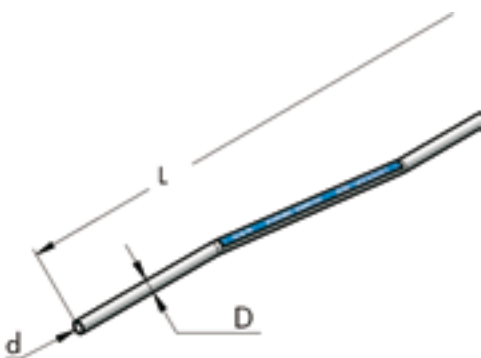
BENT PIPE FOR D14 DROP COLUMN

| D mm | d mm | L m | Part. no. | P g |  | n° |
|---------|---------|--------|--------------|--------|---|----|
| 14 | 12 | 1 | 804 014 100 | 105 | 20 | |

HANGING BRACKET, COMPLETE

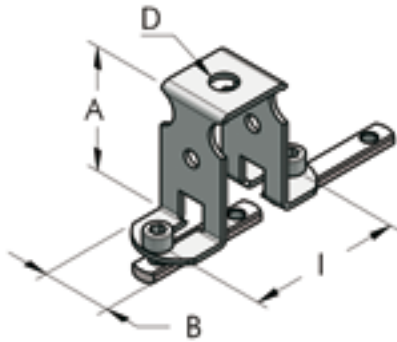

| I mm | A mm | B mm | D mm | Part. no. | P g | n° |
|---------|---------|---------|---------|--------------|--------|----|
| 36-60 | 50 | 28 | 10 | 003 001 074 | 100 | 20 |

SMALL PLATE WITH M6 HOLES

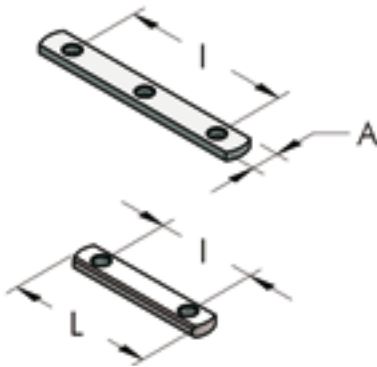

| I mm | A mm | L mm | holes | Part. no. | P g | n° |
|---------|---------|---------|-------|--------------|--------|-----|
| 36 | 10 | 56 | 2 | 725 010 056 | 12 | 100 |
| 60 | 10 | 80 | 2 | 725 010 080 | 23 | 50 |
| 60 | 10 | 78 | 3 | 725 010 081 | 22 | 50 |

INSULATING BLOCK

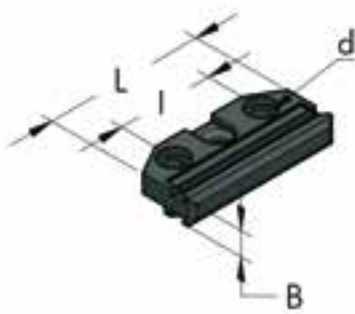

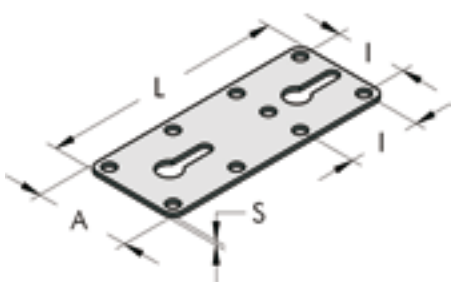

| d mm | L mm | I mm | B mm | Part. no. | P g | n° |
|---------|---------|---------|---------|--------------|--------|----|
| 6 | 60 | 36 | 10 | 003 001 075 | 26 | 20 |

STRAIGHT PLATE, IN GALVANIZED STEEL

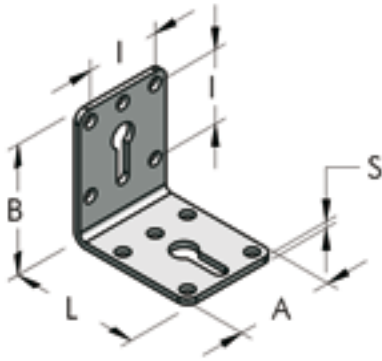

| A mm | L mm | I mm | S mm | Part. no. | P g | n° |
|---------|---------|---------|---------|--------------|--------|----|
| 48 | 120 | 36 | 2 | 711 048 120 | 80 | 20 |
| 54 | 160 | 36 | 2,5 | 711 056 160 | 146 | 20 |
| 72 | 160 | 36-60 | 2,5 | 711 072 160 | 201 | 20 |
| 78 | 240 | 36-60 | 3,5 | 711 078 230 | 422 | 20 |

L PLATE, IN GALVANIZED STEEL

| A mm | B mm | L mm | I mm | S mm | Part. no. | P g |  n° |
|---------|---------|---------|---------|---------|--------------|--------|---|
| 48 | 60 | 60 | 36 | 2 | 721 048 060 | 77 | 20 |
| 54 | 80 | 80 | 36 | 2,5 | 732 056 080 | 148 | 20 |
| 72 | 80 | 80 | 36-60 | 3 | 732 072 090 | 245 | 20 |
| 78 | 94 | 140 | 36-60 | 3,5 | 732 078 140 | 420 | 20 |

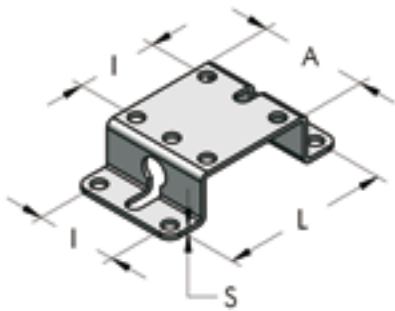
FIXING BRACKET, IN GALVANIZED STEEL

| A mm | L mm | I mm | S mm | Part. no. | P g |  n° |
|---------|---------|---------|---------|--------------|--------|--|
| 48 | 72 | 36 | 2 | 735 048 120 | 78 | 20 |

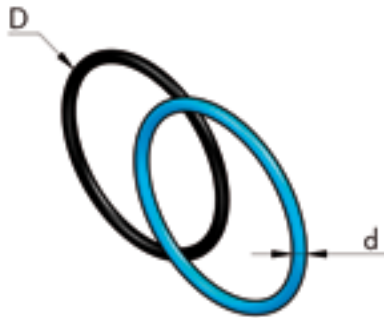
O-RING SEAL IN NBR70

| D mm | d mm | Cod. AS/BS NORM | Part. no. | P g |  n° |
|---------|---------|--------------------|--------------|--------|---|
| 25 | 1,78 | 2081-019 | 271 020 002 | 0,4 | 100 |
| 25 | 2 | 0210-02 | 271 021 002 | 0,5 | 100 |
| 29 | 3 | 0230-03 | 271 023 003 | 0,7 | 100 |
| 32 | 2,62 | 3106-121 | 271 027 003 | 0,7 | 100 |
| 32 | 3 | 0260-03 | 271 026 003 | 0,8 | 100 |
| 50 | 2,62 | 3175-132 | 271 044 003 | 1 | 100 |
| 50 | 3 | 0440-03 | 271 043 003 | 1,3 | 100 |
| 63 | 2,62 | 3225-140 | 271 057 003 | 1,2 | 100 |
| 63 | 3 | 0560-03 | 271 056 003 | 1,5 | 100 |
| 80 | 3 | 0720-03 | 271 072 003 | 2,2 | 100 |
| 80 | 2,62 | 3287-150 | 271 073 003 | 1,5 | 100 |
| 110 | 3,53 | 4387-241 | 271 101 004 | 4 | 100 |

FLAT SEAL FOR FLANGES

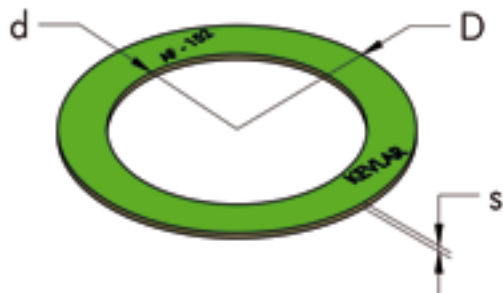

| D mm | d mm | DN | S mm | Part. no. | P g | n° | |
|---------|---------|-----|---------|--------------|--------|----|--|
| 142 | 90 | 80 | 2 | 274 089 002 | 33 | 10 | |
| 160 | 116 | 100 | 3 | 274 116 003 | 56 | 10 | |

ALLEN SCREW, IN GALVANIZED STEEL

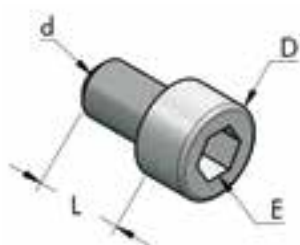

| d mm | L mm | D mm | E mm | Part. no. | P g | n° | |
|---------|---------|---------|---------|--------------|--------|-----|--|
| M6 | 8 | 10 | 5 | 212 006 008 | 4,2 | 100 | |
| M6 | 10 | 10 | 5 | 212 006 010 | 4,5 | 100 | |
| M6 | 12 | 10 | 5 | 212 006 012 | 4,8 | 100 | |
| M6 | 14 | 10 | 5 | 212 006 014 | 5,0 | 100 | |
| M6 | 18 | 10 | 5 | 212 006 018 | 5,8 | 100 | |

DRILLING JIG

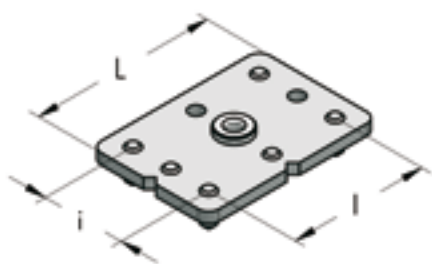

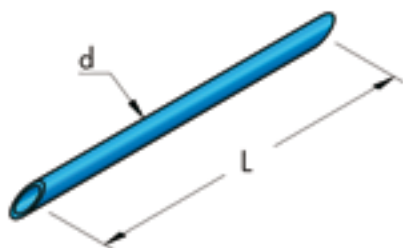

| I mm | i mm | L mm | Part. no. | P g | n° | |
|---------|---------|---------|--------------|--------|----|--|
| 60 | 36 | 80 | 911 036 060 | 190 | 1 | |

TUBES TO HOLD SMALL PLATE IN POSITION

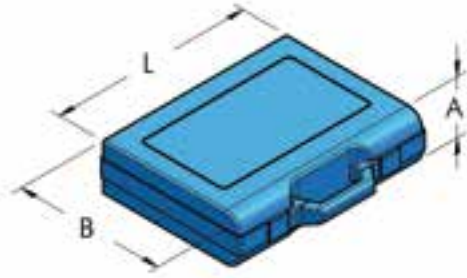

| d mm | L mm | Mat | Part. no. | P g | n° | |
|---------|---------|-----|--------------|--------|----|--|
| 8 | 150 | PVC | 421 006 015 | 5 | 10 | |

BASIC TOOLS BOX

| A mm | B mm | L mm | Part. no. | P g |  n° |
|---------|---------|---------|--------------|--------|---|
| 50 | 190 | 240 | 003 001 092 | 700 | 1 |

HBS

VASELINE GREASE

| Part. no. | P g |  n° |
|--------------|--------|---|
| 111 003 100 | 850 | 20 |
| 111 003 010 | 100 | 20 |

PTFE BLUE GREASE

| Part. no. | P g |  n° |
|--------------|--------|---|
| 114 003 005 | 50 | 20 |

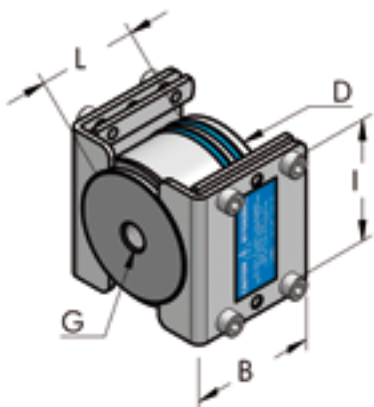
TERMINAL WITH NPT THREADED HOLE, COMPLETE

| D mm | G | L mm | B mm | I mm | Part. no. | P g | n° | |
|---------|------------|---------|---------|---------|--------------|--------|----|--|
| 25 | 1/4" - NPT | 22 | 60 | 36 | 003 000 425 | 114 | 20 | |
| 32 | 1/4" - NPT | 25 | 60 | 36 | 003 001 425 | 130 | 20 | |
| 32 | 1/2" - NPT | 25 | 60 | 36 | 003 001 431 | 128 | 20 | |
| 50 | 1/4" - NPT | 40 | 60 | 36 | 003 002 425 | 440 | 20 | |
| 50 | 1/2" - NPT | 40 | 60 | 36 | 003 002 429 | 430 | 20 | |
| 63 | 1/4" - NPT | 50 | 60 | 60 | 003 003 425 | 656 | 20 | |
| 80 | 1/4" - NPT | 66 | 80 | 60 | 003 004 425 | 1300 | 20 | |
| 80 | 1/2" - NPT | 66 | 80 | 60 | 003 004 429 | 1300 | 20 | |
| 110 | 3/8" - NPT | 150 | 110 | 60 | 003 005 425 | 2000 | 20 | |

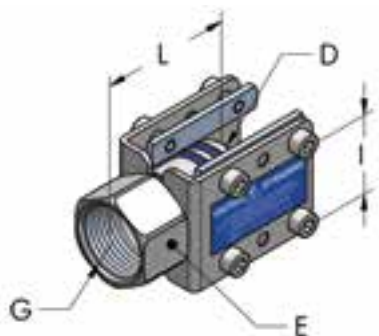
NPT TERMINAL THREADED FEMALE, COMPLETE

| D mm | G | E mm | L mm | I mm | Part. no. | P g | n° | |
|---------|--------------|---------|---------|---------|--------------|--------|----|--|
| 25 | 3/4" - NPT | 30 | 40 | 36 | 003 000 427 | 120 | 20 | |
| 32 | 1" - NPT | 36 | 50 | 36 | 003 001 427 | 140 | 20 | |
| 50 | 1 1/2" - NPT | 52 | 70 | 36 | 003 002 428 | 340 | 20 | |
| 63 | 1 1/2" - NPT | 65 | 75 | 60 | 003 003 428 | 440 | 10 | |
| 80 | 1" - NPT | - | 66 | 60 | 003 004 427 | 920 | 20 | |
| 80 | 2" - NPT | 82 | 95 | 60 | 003 004 428 | 920 | 10 | |
| 110 | 2 1/2" - NPT | 115 | 150 | 60 | 003 005 428 | 2000 | 20 | |

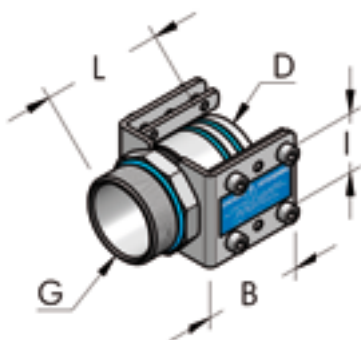

NPT NIPPLE THREADED MALE, COMPLETE

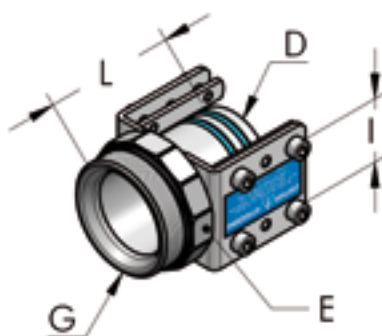
| D mm | G | L mm | B mm | I mm | Part. no. | P g | n° | |
|---------|--------------|---------|---------|---------|--------------|--------|----|--|
| 25 | 3/4" - NPT | 36 | 60 | 36 | 003 000 429 | 110 | 20 | |
| 32 | 1" - NPT | 44 | 60 | 36 | 003 001 430 | 230 | 20 | |
| 50 | 1 1/2" - NPT | 75 | 60 | 36 | 003 002 430 | 330 | 20 | |
| 63 | 2" - NPT | 80 | 60 | 60 | 003 003 430 | 430 | 10 | |
| 80 | 2 1/2" - NPT | 102 | 80 | 60 | 003 004 430 | 650 | 10 | |



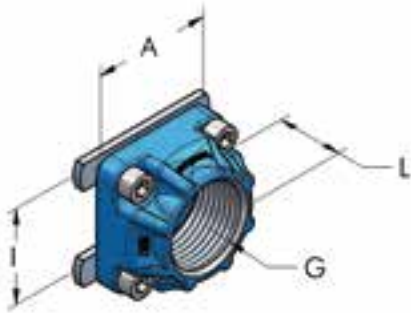



NPT TERMINAL THREADED MALE, COMPLETE

| D mm | G | L mm | E mm | I mm | Part. no. | P g | n° | |
|---------|--------------|---------|---------|---------|--------------|--------|----|--|
| 25 | 1" - NPT | 40 | 36 | 36 | 003 000 430 | 130 | 20 | |
| 32 | 1 1/4" - NPT | 52 | 50 | 36 | 003 001 429 | 190 | 20 | |
| 50 | 2" - NPT | 75 | 65 | 36 | 003 002 431 | 440 | 20 | |
| 63 | 2 1/2" - NPT | 90 | 82 | 60 | 003 003 431 | 600 | 10 | |
| 80 | 3" - NPT | 120 | 90 | 60 | 003 004 431 | 830 | 10 | |
| 110 | 4" - NPT | 150 | 115 | 60 | 003 005 431 | 1500 | 20 | |



I36 NPT FEMALE OUTLET PLATE, COMPLETE

| I mm | G | A mm | L mm | Part. no. | P g | n° |  |
|---------|------------|---------|---------|--------------|--------|----|---|
| 36 | 1/8" - NPT | 50 | 25 | 003 001 432 | 80 | 20 |  |
| 36 | 1/4" - NPT | 50 | 25 | 003 001 433 | 80 | 20 | |
| 36 | 3/8" - NPT | 50 | 25 | 003 001 434 | 80 | 20 | |
| 36 | 1/2" - NPT | 50 | 25 | 003 002 433 | 110 | 20 | |
| 36 | 3/4" - NPT | 50 | 25 | 003 002 434 | 105 | 20 | |
| 36 | 1" - NPT | 50 | 25 | 003 002 435 | 90 | 20 | |



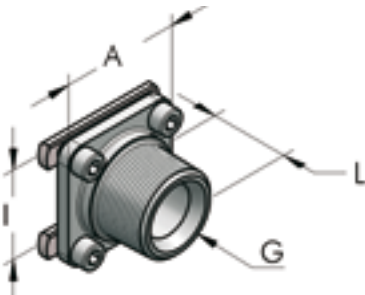

I60 NPT FEMALE OUTLET PLATE, COMPLETE

| I mm | G | A mm | L mm | Part. no. | P g | n° |  |
|---------|--------------|---------|---------|--------------|--------|----|---|
| 60 | 1/2" - NPT | 70 | 30 | 003 003 433 | 250 | 10 | |
| 60 | 3/4" - NPT | 72 | 30 | 003 003 434 | 220 | 20 |  |
| 60 | 1" - NPT | 72 | 30 | 003 003 435 | 200 | 10 |  |
| 60 | 1 1/4" - NPT | 72 | 30 | 003 003 438 | 175 | 10 |  |
| 60 | 1 1/2" - NPT | 72 | 30 | 003 003 436 | 150 | 10 |  |
| 60 | 2" - NPT | 72 | 30 | 003 003 439 | 193 | 10 |  |

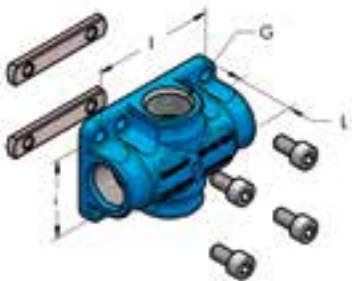





NPT MALE OUTLET PLATE, COMPLETE

| I mm | G | A mm | L mm | Part. no. | P g | n° |  |
|---------|----------|---------|---------|--------------|--------|----|---|
| 36 | 1" - NPT | 48 | 36 | 003 002 436 | 120 | 20 | |
| 60 | 2" - NPT | 70 | 49 | 003 004 436 | 600 | 10 |  |

NPT FEMALE MULTIPLE OUTLETS PLATE, COMPLETE

| I mm | i mm | holes | G | L mm | Part no | P g | n° |  |
|---------|---------|-------|------------|---------|-------------|--------|----|---|
| 60 | 36 | 4 | 1/4" - NPT | 30 | 003 360 454 | 190 | 10 |  |
| 60 | 36 | 4 | 3/8" - NPT | 30 | 003 360 456 | 175 | 10 |  |
| 60 | 36 | 4 | 1/2" - NPT | 30 | 003 360 458 | 150 | 10 |  |
| 60 | 36 | 2 | 1/2" - NPT | 30 | 003 360 459 | 160 | 10 |  |

FLEXIBLE PIPE WITH NPT THREADED TERMINAL FOR CONNECTION TO COMPRESSOR

| D mm | G | L mm | d mm | Part. no. | P g | n° |  |
|---------|--------------|---------|---------|--------------|--------|----|---|
| 25 | 1" - NPT | 1000 | 37 | 003 000 458 | 1700 | 20 |  |
| 32 | 1 1/4" - NPT | 1000 | 44 | 003 001 458 | 2200 | 20 |  |
| 50 | 2" - NPT | 1000 | 65 | 003 002 458 | 4000 | 20 |  |
| 63 | 2 1/2" - NPT | 1300 | 77 | 003 003 458 | 4700 | 20 |  |
| 80 | 3" - NPT | 1600 | 90 | 003 004 458 | 5800 | 20 |  |

COMPRESSED AIR AND FLUIDS PIPING SYSTEMS



MODULAR MANIFOLDS INTEGRATED ON MACHINES

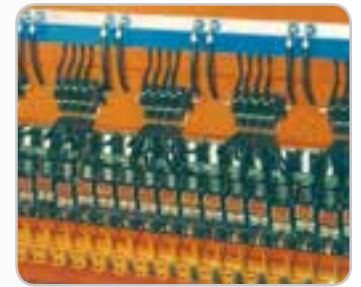

ASSEMBLY AND PRODUCTION LINES





AP MODULAR PIPING SYSTEM

This product patented by Teseo is the result of years of research and experience in installing thousands of distribution systems made up of aluminium profiles all over the world. AP is suitable for compressed air distribution lines or for main line drops.

The following advantages stand out:

- Easy and quick to assemble, no special tools required, it can be assembled without special skills.
- Its simple section is symmetric and can be used on all the sides. Easy to cut and bend.
- Equipped with numerous accessories which are designed of simple modular elements compatible both with the present HBS system and steel pipes with "Gas" BSP or NPT threads.
- A very competitive price, thanks to the quick mounting, AP is more convenient than a traditional piping system.

EASY TO ASSEMBLE

DEBURRING



MOUNTING



ASSEMBLING



TIGHTENING

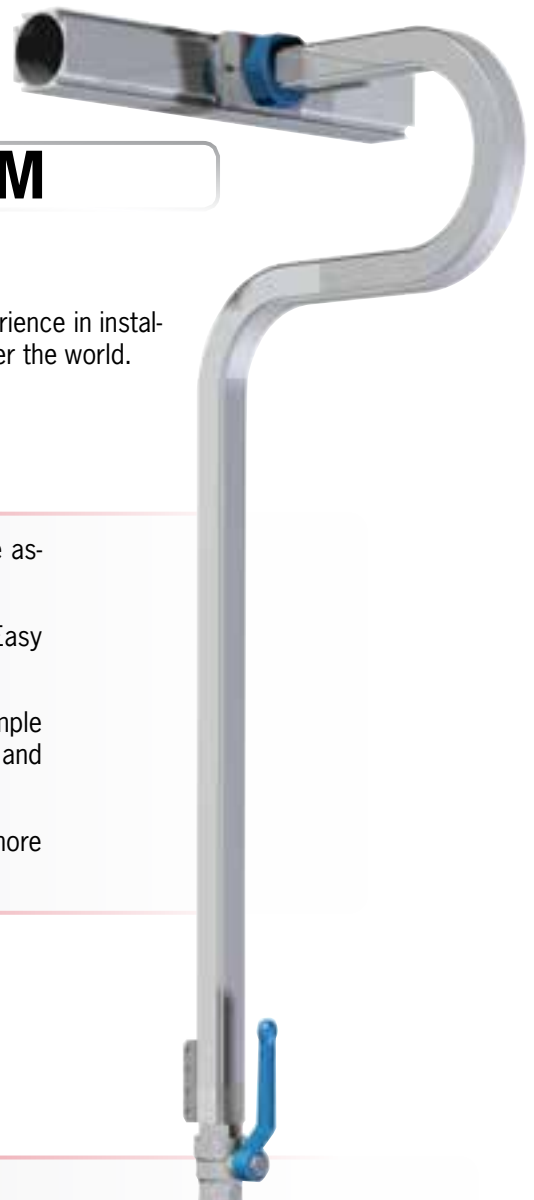

BLUE DESIGN

The new generation of “blue” in **TESEO** is the result of the modification and the improvement of all the Teseo systems. Our continuous research into **Energy Saving** together with a high regard for the **Design** ruled our technical choices. We studied the internal passages and the thicknesses to increase the flow rate.

Double seats for the O-rings and high quality NBR **Blue O-Rings**, manufactured for Teseo, are applied to all the connections for a better sealing.

Ergonomics of the complete system has been improved thanks to optimization of the shapes and weights. Precision manufacturing carried out on many components improves the outer finishing and removes the die-casting defects.

Outlet plates have been re designed with new moulds, to improve quality and accuracy. The blocking parts have been analyzed and improved.

The implementation of accessories and components is continuous.

Teseo are sourcing **New certifications** and international confirmation.



Indicative diagram for the choice of the AP diameter according to compressor installed max power

| Compressor power | AP | Indicative flow rate (L 30m - 6 bar - Δp 3%) |
|------------------|----|---|
| kW | | l/min |
| 11 | 22 | 1.650 |
| 19 | 28 | 2.900 |
| 36 | 36 | 5.400 |
| 67 | 45 | 10.000 |
| 110 | 54 | 16.400 |
| 195 | 68 | 29.200 |



Indicative diagrams of compressed air flow rates and related pressure drops in a line 30 m long (20°C - 1013 mbar). The data used has been provided by the POLYTECHNIC INSTITUTE OF TURIN.

See online software (page 9)

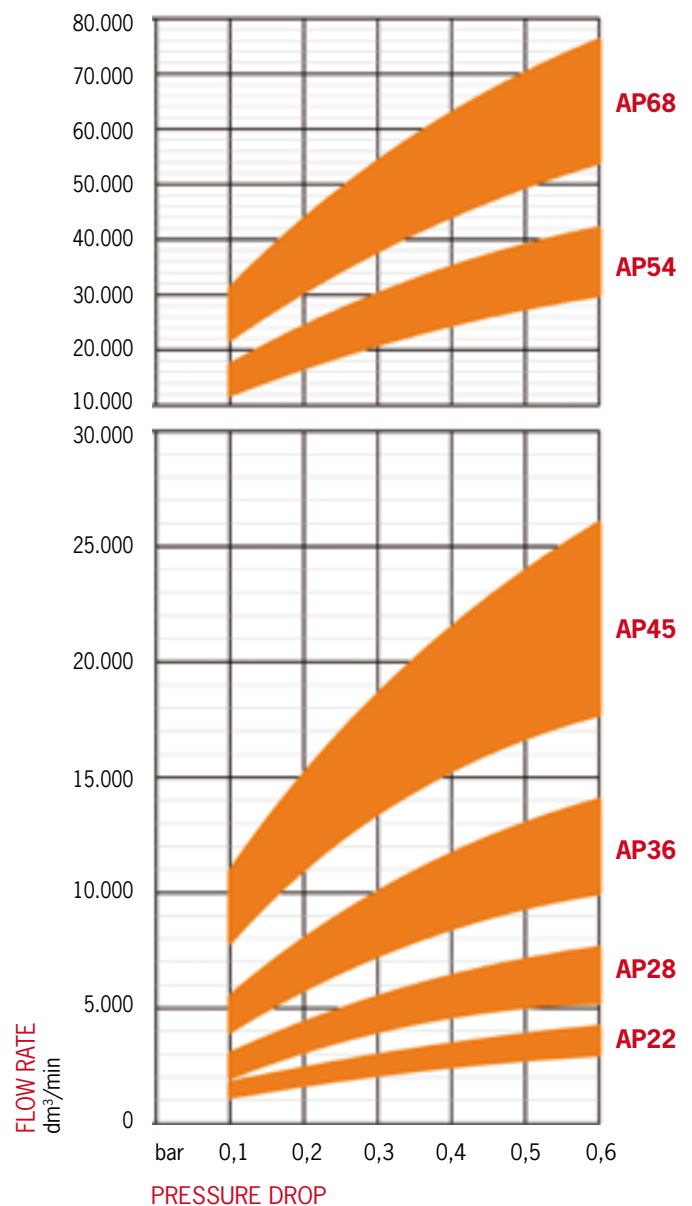

AIR PRESSURE: 6 → 12 bar
0,6 → 1,2 MPa
87 → 174 psi

TECHNICAL CHARACTERISTICS

| | |
|---|---|
| Extruded Aluminium..... | Alloy EN AW 6060 UNI EN 573-3:1996 |
| International designations..... | ANSI 6060 - DIN 1748/1: AlMgSi 0,5 BS 6060 |
| Chemical composition..... | Si: 0,45% - Mg: 0,45% - Fe: 0,3% |
| Heat treatment..... | Aging T5 o T6 |
| Surface treatment (upon request) | Chemical silver anodization |
| Specific weight, density | Kg/dm³ 2,71 |
| Electrical conductivity | % IACS 53 |
| Thermal Conductivity..... | W/m.K 200 |
| Specific heat..... | J/Kg.K 96 |
| Coefficient of expansion..... | mm/m °C 0,024 |
| Tensile strength..... | Kg/mm² 24 |
| Yield strength..... | Kg/mm² 20 |
| Modulus of elasticity..... | Kg/mm² 6.700 |
| Brinell hardness | HB 70÷80 |
| Melting range | °C 600-650 |
| O-ring material | NBR 70 |
| Operating temperature | °C -20/+120 |
| Screw material | Steel Class 8.8 |
| M5 Screw driving torque..... | 10 N·m (90 Inch·Lbs) ± 10% |
| M6 Screw driving torque..... | 14 N·m (120 Inch·Lbs) ± 10% |
| Outlet thread..... | BSP or NPT |
| Terminal thread | BSP or NPT |
| Max operating pressure | 15 bar - 1,5 MPa - 217 psi |
| Powering multfluid, max operating pressure..... | 25 bar - 2,5 MPa - 362 psi |
| Failure test pressure..... | 80 bar - 8 MPa - 1160 psi |

Compatibility with fluids

Compressed air, Vacuum, Argon, Nitrogen, Carbon dioxide, Mineral oil*, Synthetic oil*, Other fluids*

WARNING!

Teseo components are intended only to uses for which they have been specifically designed by the manufacturer and patent holder. This does not absolve the professional user to refrain from checking technical compatibility and current project of your application. Our technical department is at your disposal for evaluations, analysis of special use, to design and eventually implement specific components and assemblies. Teseo company is not responsible for any damage caused by improper, erroneous, unreasonable and product incompatibilities with applications not specified by the catalog.

*For further information, please apply to Teseo Srl Technical Office.

PROFILES SECTION OVER VIEW

AP22

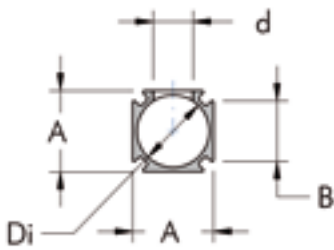

AP28

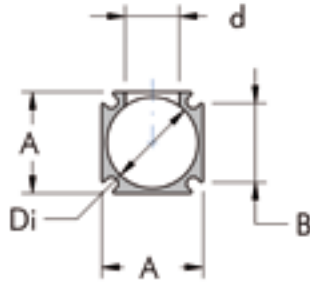

AP36

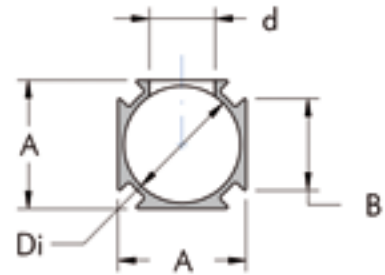

AP68

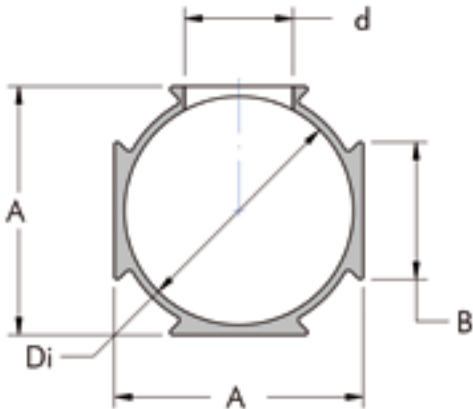

AP54

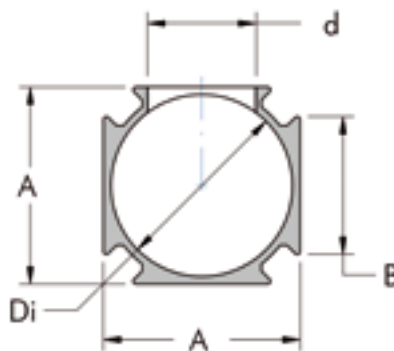

AP45

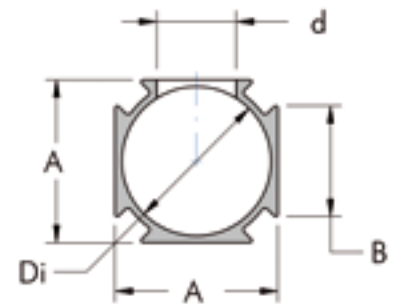

SIZE DIMENSIONS

| Name | Dimensions | | | | Max hole | Weight | Moment of inertia | | Inner volume |
|------|------------|---------|---------|---------|----------|--------|-----------------------|-----------------------|--------------|
| | Di mm | A mm | B mm | d mm | | | Jx cm ⁴ | Jy cm ⁴ | |
| AP22 | 20 | 22,4 | 16,4 | 11 | 370 | 0,90 | 0,90 | 0,32 | |
| AP28 | 25 | 28 | 21,5 | 15 | 590 | 2,20 | 2,20 | 0,5 | |
| AP36 | 32 | 36 | 25 | 18 | 780 | 4,60 | 4,60 | 0,8 | |
| AP45 | 40 | 45 | 31 | 22 | 1170 | 11,00 | 11,00 | 1,3 | |
| AP54 | 50 | 55 | 38 | 30 | 1690 | 23,70 | 23,70 | 2 | |
| AP68 | 63 | 69 | 38 | 30 | 2080 | 44,10 | 44,10 | 3,1 | |

NATURAL ALUMINIUM EXTRUDED PIPE

POW

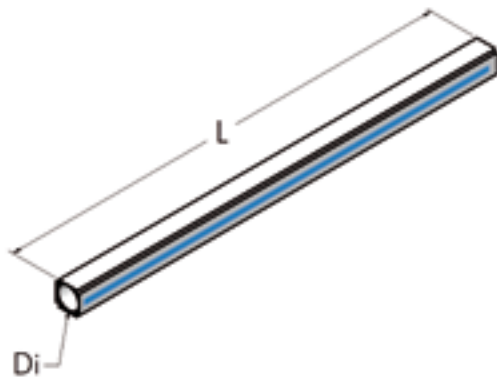

| Di mm | L m | Part. no. | P kg | n° | |
|----------|--------|--------------|---------|-----|--|
| 20 | 5 | 800 020 500 | 1,9 | 100 | |
| 25 | 5 | 800 025 500 | 3 | 64 | |
| 32 | 5 | 800 032 500 | 3,9 | 36 | |
| 40 | 5 | 800 040 500 | 5,8 | 36 | |
| 50 | 5 | 800 050 500 | 8,4 | 16 | |
| 63 | 5 | 800 063 500 | 10,4 | 16 | |

| Di mm | L m | Part. no. | P kg | n° | |
|----------|--------|--------------|---------|-----|--|
| 20 | 2,5 | 800 020 250 | 0,95 | 100 | |
| 25 | 2,5 | 800 025 250 | 1,5 | 64 | |
| 32 | 2,5 | 800 032 250 | 1,95 | 36 | |
| 40 | 2,5 | 800 040 250 | 2,9 | 36 | |
| 50 | 2,5 | 800 050 250 | 4,2 | 16 | |
| 63 | 2,5 | 800 063 250 | 5,2 | 16 | |

ANODIZED ALUMINIUM EXTRUDED PIPE

POW

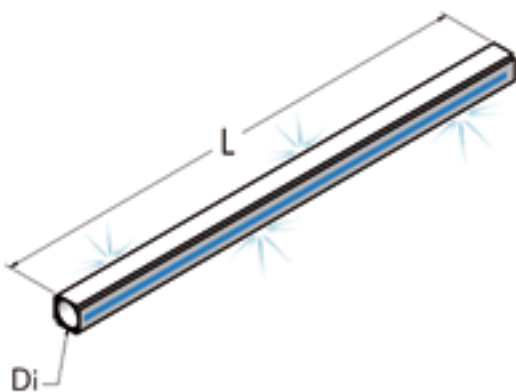



| Di mm | L m | Part. no. | P kg | n° | |
|----------|--------|--------------|---------|-----|--|
| 20 | 5 | 801 020 500 | 1,9 | 100 | |
| 25 | 5 | 801 025 500 | 3 | 64 | |
| 32 | 5 | 801 032 500 | 3,9 | 36 | |
| 40 | 5 | 801 040 500 | 5,8 | 36 | |
| 50 | 5 | 801 050 500 | 8,4 | 16 | |
| 63 | 5 | 801 063 500 | 10,4 | 16 | |

| Di mm | L m | Part. no. | P kg | n° | |
|----------|--------|--------------|---------|-----|--|
| 20 | 2,5 | 801 020 250 | 0,95 | 100 | |
| 25 | 2,5 | 801 025 250 | 1,5 | 64 | |
| 32 | 2,5 | 801 032 250 | 1,95 | 36 | |
| 40 | 2,5 | 801 040 250 | 2,9 | 36 | |
| 50 | 2,5 | 801 050 250 | 4,2 | 16 | |
| 63 | 2,5 | 801 063 250 | 5,2 | 16 | |

POW

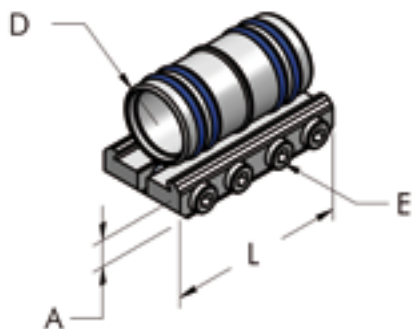



STRAIGHT JOINT, COMPLETE

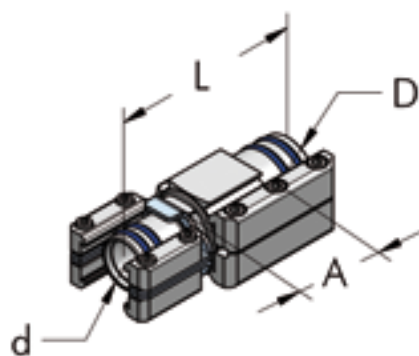

| D mm | L mm | A mm | E mm | Part. no. | P g | n° | |
|---------|---------|---------|---------|--------------|--------|----|---|
| 20 | 46 | 9 | 4 | 006 020 020 | 39 | 10 | |
| 25 | 60 | 10 | 4 | 006 025 020 | 86 | 10 | |
| 32 | 95 | 11 | 4 | 006 032 020 | 170 | 10 |  |
| 40 | 80 | 12 | 5 | 006 040 020 | 200 | 10 | |
| 50 | 150 | 12 | 5 | 006 050 020 | 395 | 10 | |
| 63 | 150 | 12 | 5 | 006 063 020 | 480 | 10 | |

REDUCTION STRAIGHT JOINT, COMPLETE



| D mm | d mm | A mm | L mm | Part. no. | P g | n° | |
|---------|---------|---------|---------|--------------|--------|----|---|
| 25 | 20 | 55 | 100 | 006 025 051 | 170 | 5 |  |
| 32 | 25 | 33 | 90 | 006 032 051 | 295 | 5 |  |
| 40 | 32 | 55 | 120 | 006 040 051 | 495 | 5 |  |
| 50 | 40 | 45 | 115 | 006 050 051 | 880 | 5 |  |
| 63 | 50 | 15 | 90 | 006 063 051 | 1030 | 5 |  |

L JOINT, COMPLETE



| D mm | L mm | B mm | Part. no. | P g | n° | |
|---------|---------|---------|--------------|--------|----|--|
| 20 | 40 | 22 | 006 020 022 | 90 | 10 | |
| 25 | 50 | 30 | 006 025 022 | 135 | 10 | |
| 32 | 45 | 42 | 006 032 022 | 260 | 10 | |
| 40 | 75 | 50 | 006 040 022 | 430 | 10 | |
| 50 | 100 | 57 | 006 050 022 | 780 | 10 | |
| 63 | 100 | 72 | 006 063 022 | 910 | 10 | |

T JOINT, COMPLETE

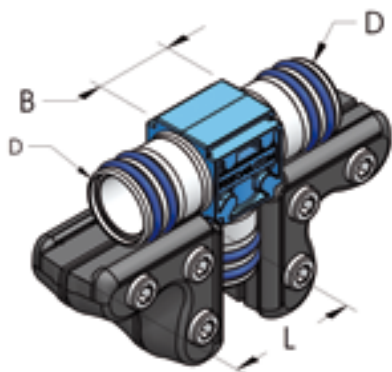

| D mm | L mm | B mm | Part. no. | P g | n° | |
|---------|---------|---------|--------------|--------|----|--|
| 20 | 40 | 24 | 006 020 024 | 150 | 10 | |
| 25 | 50 | 30 | 006 025 024 | 240 | 10 | |
| 32 | 45 | 50 | 006 032 024 | 430 | 10 | |
| 40 | 75 | 53 | 006 040 024 | 730 | 10 | |
| 50 | 100 | 60 | 006 050 024 | 1325 | 10 | |
| 63 | 100 | 76 | 006 063 024 | 1530 | 10 | |

CLOSED TERMINAL, COMPLETE

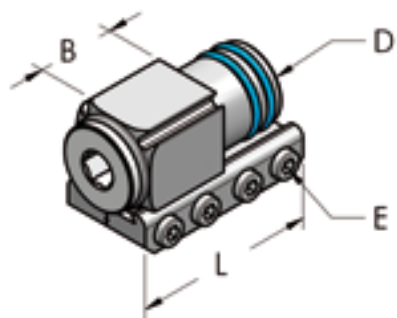

| D mm | L mm | E mm | B mm | Part. no. | P g | n° | |
|---------|---------|---------|---------|--------------|--------|----|--|
| 20 | 46 | 4 | 24 | 006 020 026 | 70 | 10 | |
| 25 | 60 | 4 | 28 | 006 025 026 | 125 | 10 | |
| 32 | 46 | 4 | 30 | 006 032 026 | 220 | 10 | |
| 40 | 80 | 5 | 35 | 006 040 026 | 300 | 10 | |
| 50 | 150 | 5 | 75 | 006 050 026 | 710 | 10 | |
| 63 | 90 | 5 | - | 006 063 026 | 700 | 10 | |

BALL VALVE, COMPLETE

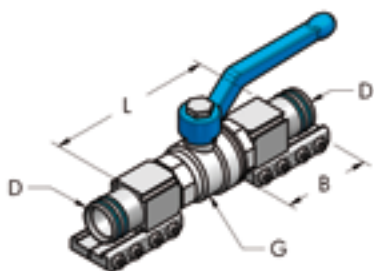







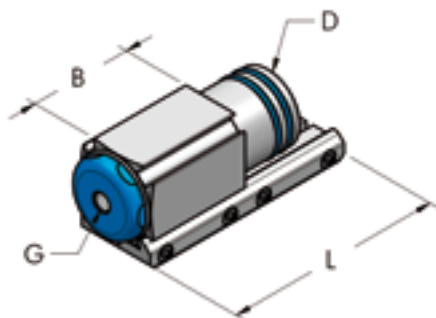

| D mm | G | L mm | B mm | Part. no. | P g | n° | |
|---------|--------------|---------|---------|--------------|--------|----|--|
| 20 | 1/2" - BSP | 100 | 46 | 006 020 046 | 290 | 10 | |
| 25 | 3/4" - BSP | 118 | 56 | 006 025 046 | 500 | 10 | |
| 32 | 1" - BSP | 90 | 46 | 006 032 046 | 830 | 10 | |
| 40 | 1 1/4" - BSP | 150 | 70 | 006 040 046 | 1250 | 10 | |
| 50 | 1 1/2" - BSP | 245 | 150 | 006 050 046 | 2450 | 10 | |
| 63 | 2" - BSP | 150 | 90 | 006 063 046 | 3300 | 10 | |

TERMINAL WITH THREADED HOLE, COMPLETE

POW





| D mm | G | L mm | B mm | Part. no. | P g | n° | |
|---------|------------|---------|---------|--------------|--------|----|---|
| 32 | 1/4" - BSP | 46 | 30 | 006 032 025 | 200 | 10 |  |
| 32 | 1/2" - BSP | 46 | 30 | 006 032 031 | 200 | 10 |  |
| 40 | 1/8" - BSP | 80 | 35 | 006 040 015 | 295 | 10 |  |
| 40 | 1/4" - BSP | 80 | 35 | 006 040 025 | 260 | 10 | |
| 40 | 3/8" - BSP | 80 | 35 | 006 040 016 | 290 | 10 |  |
| 40 | 1/2" - BSP | 80 | 35 | 006 040 017 | 280 | 10 | |
| 40 | 3/4" - BSP | 80 | 35 | 006 040 018 | 270 | 10 |  |
| 50 | 1/8" - BSP | 150 | 75 | 006 050 015 | 705 | 10 |  |
| 50 | 1/4" - BSP | 150 | 75 | 006 050 025 | 700 | 10 | |
| 50 | 1/2" - BSP | 150 | 75 | 006 050 017 | 690 | 10 | |
| 50 | 3/4" - BSP | 150 | 75 | 006 050 018 | 670 | 10 |  |
| 50 | 1" - BSP | 150 | 75 | 006 050 019 | 655 | 10 | |
| 63 | 1/4" - BSP | 90 | - | 006 063 025 | 660 | 10 |  |

TERMINAL THREADED FEMALE, COMPLETE

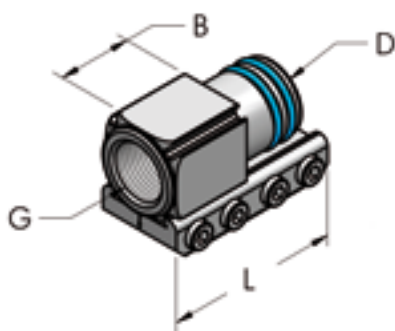
POW





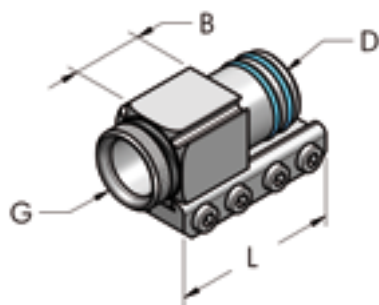

| D mm | G | L mm | B mm | Part. no. | P g | n° | |
|---------|--------------|---------|---------|--------------|--------|----|---|
| 20 | 3/8" - BSP | 46 | 24 | 006 020 028 | 54 | 10 | |
| 25 | 1/2" - BSP | 60 | 28 | 006 025 028 | 105 | 10 | |
| 32 | 1" - BSP | 46 | 23 | 006 032 027 | 205 | 10 |  |
| 40 | 1" - BSP | 80 | 35 | 006 040 027 | 260 | 10 | |
| 50 | 1 1/4" - BSP | 150 | 75 | 006 050 027 | 615 | 10 | |
| 50 | 1 1/2" - BSP | 150 | 75 | 006 050 028 | 565 | 10 | |
| 63 | 1 1/2" - BSP | 90 | 20 | 006 063 028 | 430 | 10 |  |

TERMINAL THREADED MALE, COMPLETE

POW



| D mm | G | L mm | B mm | Part. no. | P g | n° | |
|---------|--------------|---------|---------|--------------|--------|----|---|
| 20 | 1/2" - BSP | 46 | 24 | 006 020 030 | 57 | 10 | |
| 25 | 3/4" - BSP | 60 | 28 | 006 025 030 | 110 | 10 | |
| 32 | 1" - BSP | 46 | 11 | 006 032 030 | 200 | 10 |  |
| 32 | 1 1/4" - BSP | 46 | 13 | 006 032 029 | 255 | 10 |  |
| 40 | 1 1/4" - BSP | 80 | 35 | 006 040 029 | 245 | 10 | |
| 50 | 1 1/2" - BSP | 150 | 75 | 006 050 029 | 655 | 10 | |
| 63 | 2" - BSP | 90 | 12 | 006 063 030 | 390 | 10 |  |
| 63 | 2 1/2" - BSP | 90 | 13 | 006 063 031 | 450 | 10 |  |

FEMALE OUTLET PLATE, COMPLETE

POW

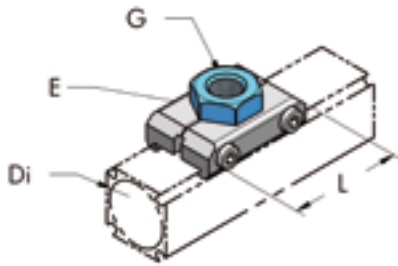

| Di mm | G | L mm | E mm | Part. no. | P g | n° | |
|----------|------------|---------|---------|--------------|--------|----|--|
| 20 | 1/4" - BSP | 46 | 22 | 006 020 033 | 36 | 10 | |
| 20 | 3/8" - BSP | 46 | 22 | 006 020 034 | 40 | 10 | |
| 25 | 1/4" - BSP | 46 | 22 | 006 025 033 | 37 | 10 | |
| 25 | 3/8" - BSP | 46 | 22 | 006 025 034 | 46 | 10 | |
| 25 | 1/2" - BSP | 46 | 30 | 006 025 035 | 55 | 10 | |
| 32 | 1/4" - BSP | 50 | 30 | 006 032 033 | 70 | 10 | |
| 32 | 3/8" - BSP | 50 | 30 | 006 032 034 | 65 | 10 | |
| 32 | 1/2" - BSP | 50 | 30 | 006 032 035 | 70 | 10 | |
| 40 | 1/8" - BSP | 70 | 36 | 006 040 032 | 148 | 10 | |
| 40 | 1/4" - BSP | 70 | 36 | 006 040 033 | 140 | 10 | |
| 40 | 3/8" - BSP | 70 | 36 | 006 040 034 | 135 | 10 | |
| 40 | 1/2" - BSP | 70 | 36 | 006 040 035 | 130 | 10 | |
| 40 | 3/4" - BSP | 70 | 36 | 006 040 036 | 120 | 10 | |
| 50/63 | 1/4" - BSP | 74 | 50 | 006 050 033 | 195 | 10 | |
| 50/63 | 1/2" - BSP | 74 | 50 | 006 050 034 | 190 | 10 | |
| 50/63 | 3/4" - BSP | 74 | 50 | 006 050 035 | 215 | 10 | |
| 50/63 | 1" - BSP | 74 | 50 | 006 050 036 | 195 | 10 | |

MALE OUTLET PLATE, COMPLETE

POW

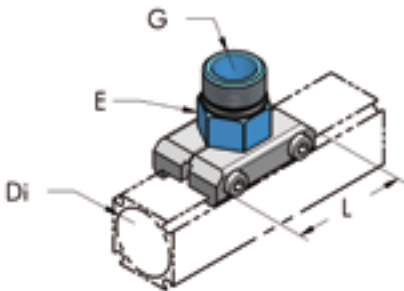





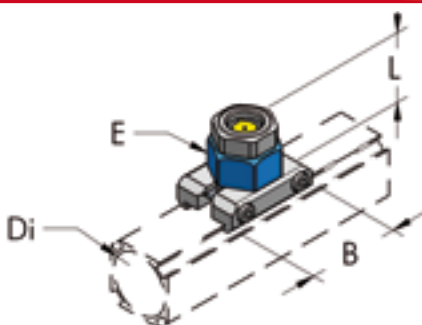



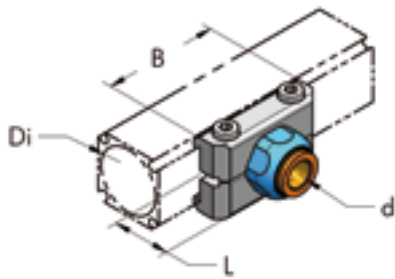

| Di mm | G | L mm | E mm | Part. no. | P g | n° | |
|----------|-------------|---------|---------|--------------|--------|----|--|
| 20 | 3/8" - BSP | 46 | 22 | 006 020 063 | 36 | 10 | |
| 25 | 1/2" - BSP | 46 | 22 | 006 025 064 | 49 | 10 | |
| 32 | 1/4" - BSP | 50 | 30 | 006 032 064 | 75 | 10 | |
| 32 | 3/8" - BSP | 50 | 30 | 006 032 065 | 75 | 10 | |
| 32 | 1/2" - BSP | 50 | 30 | 006 032 066 | 74 | 10 | |
| 32 | 3/4" - BSP | 50 | 30 | 006 032 067 | 72 | 10 | |
| 40 | 1/2" - BSP | 70 | 36 | 006 040 062 | 135 | 10 | |
| 40 | 3/4" - BSP | 70 | 36 | 006 040 063 | 140 | 10 | |
| 40 | 1" - BSP | 70 | 36 | 006 040 064 | 140 | 10 | |
| 50/63 | 3/4" - BSP | 74 | 50 | 006 050 063 | 190 | 10 | |
| 50/63 | 1" - BSP | 74 | 50 | 006 050 064 | 185 | 10 | |
| 50/63 | 1"1/4 - BSP | 74 | 50 | 006 050 065 | 190 | 10 | |
| 50/63 | 1"1/2 - BSP | 74 | 50 | 006 050 066 | 195 | 10 | |

CONDENSATE LEVEL SPY HOLE, COMPLETE







| Di mm | L mm | B mm | E mm | Part. no. | P g | n° | |
|----------|---------|---------|---------|--------------|--------|----|--|
| 32 | 38 | 50 | 30 | 006 032 044 | 105 | 5 | |

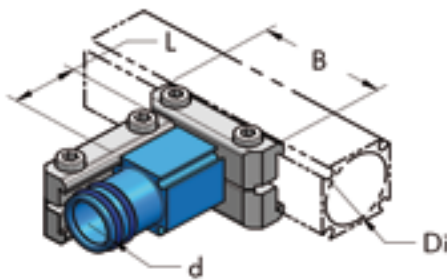



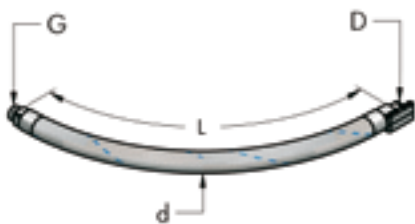

OUTLET PLATE WITH QUICKFIT, COMPLETE

| Di mm | d mm | B mm | L mm | Part. no. | P g | n° | |
|----------|---------|---------|---------|--------------|--------|----|---|
| 20 | 8 | 46 | 23 | 006 020 084 | 112 | 10 |  |
| 20 | 10 | 46 | 26 | 006 020 085 | 190 | 10 |  |
| 25 | 8 | 46 | 23 | 006 025 084 | 235 | 10 |  |
| 25 | 10 | 46 | 23 | 006 025 085 | 246 | 10 |  |
| 32 | 8 | 50 | 30 | 006 032 084 | 80 | 10 |  |
| 32 | 10 | 50 | 30 | 006 032 085 | 80 | 10 |  |
| 32 | 12 | 50 | 30 | 006 032 086 | 80 | 10 |  |
| 40 | 10 | 70 | 23 | 006 040 085 | 318 | 10 |  |
| 40 | 12 | 70 | 26 | 006 040 086 | 370 | 10 |  |





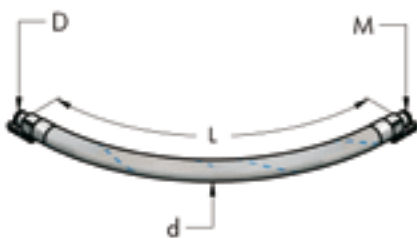

REDUCTION PLATE, COMPLETE**POW**

| Di mm | d mm | B mm | L mm | Part. no. | P g | n° | |
|----------|---------|---------|---------|--------------|--------|----|---|
| 25 | 20 | 46 | 24 | 006 020 039 | 112 | 10 | |
| 32 | 20 | 50 | 50 | 006 032 061 | 140 | 10 |  |
| 32 | 25 | 50 | 42 | 006 032 062 | 155 | 10 |  |
| 40 | 20 | 70 | 24 | 006 040 037 | 190 | 10 | |
| 40 | 25 | 70 | 28 | 006 040 038 | 235 | 10 | |
| 40 | 32 | 70 | 28 | 006 032 039 | 300 | 10 |  |
| 50/63 | 20 | 74 | 35 | 006 050 038 | 318 | 10 | |
| 50/63 | 25 | 74 | 60 | 006 050 039 | 370 | 10 | |
| 50/63 | 32 | 74 | 28 | 006 032 060 | 370 | 10 |  |
| 50/63 | 40 | 74 | 35 | 006 040 039 | 370 | 10 | |

FLEXIBLE PIPE FOR CONNECTION TO COMPRESSOR FOR COMPRESSED AIR (15 BAR)

| D mm | G | L mm | d mm | Part. no. | P g | n° | |
|---------|-------------|---------|---------|--------------|--------|----|---|
| 20 | 1/2" - BSP | 700 | 30 | 006 020 058 | 500 | 1 |  |
| 25 | 3/4" - BSP | 700 | 35 | 006 025 058 | 750 | 1 |  |
| 32 | 1"1/4 - BSP | 1000 | 44 | 006 032 058 | 2000 | 1 |  |
| 40 | 1"1/4 - BSP | 1000 | 50 | 006 040 058 | 3000 | 1 |  |
| 50 | 2" - BSP | 1000 | 65 | 006 050 058 | 4075 | 1 |  |
| 63 | 2"1/2 - BSP | 1300 | 77 | 006 063 058 | 4700 | 1 |  |

FLEXIBLE JOINT FOR AP-AP CONNECTION FOR COMPRESSED AIR (15 BAR)

| D mm | M | L mm | d mm | Part. no. | P g | n° | |
|---------|----|---------|---------|--------------|--------|----|---|
| 20 | 20 | 700 | 30 | 006 020 059 | 510 | 1 |  |
| 25 | 25 | 700 | 35 | 006 025 059 | 830 | 1 |  |
| 32 | 32 | 1000 | 44 | 006 032 059 | 2260 | 1 |  |
| 40 | 40 | 1000 | 50 | 006 040 059 | 3050 | 1 |  |
| 50 | 50 | 1000 | 65 | 006 050 059 | 4300 | 1 |  |
| 63 | 63 | 1300 | 77 | 006 063 059 | 5000 | 1 |  |

MANOMETER, COMPLETE

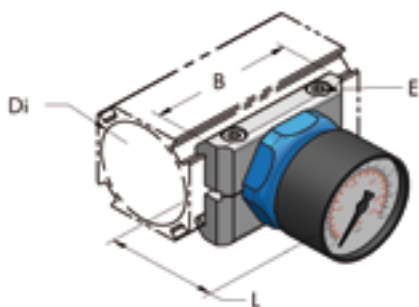

| Di mm | L mm | B mm | E mm | Part. no. | P g | n° | |
|----------|---------|---------|---------|--------------|--------|----|--|
| 20 | 58 | 46 | 4 | 006 020 048 | 70 | 10 | |
| 25 | 52 | 56 | 4 | 006 025 048 | 75 | 10 | |
| 32 | 54 | 50 | 4 | 006 032 048 | 145 | 10 | |
| 40 | 58 | 70 | 5 | 006 040 048 | 174 | 10 | |
| 50/63 | 58 | 74 | 5 | 006 050 048 | 230 | 10 | |

L PLATE, COMPLETE

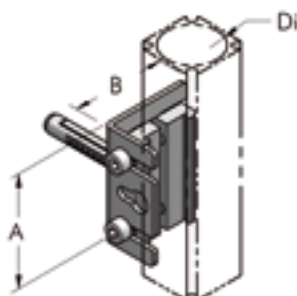

| Di mm | d mm | A mm | B mm | Part. no. | P g | n° | |
|----------|---------|---------|---------|--------------|--------|----|--|
| 20 | 8 | 50 | 40 | 006 020 040 | 70 | 10 | |
| 25 | 8 | 50 | 40 | 006 025 040 | 75 | 10 | |
| 32 | 8 | 80 | 60 | 006 032 040 | 127 | 10 | |
| 40 | 8 | 80 | 60 | 006 040 040 | 140 | 10 | |
| 50/63 | 8 | 80 | 60 | 006 050 040 | 160 | 10 | |

SNAP CLAMP, COMPLETE

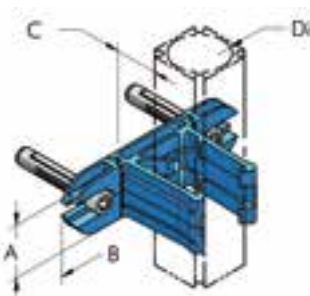

| Di mm | A mm | B mm | C mm | Part. no. | P g | n° | |
|----------|---------|---------|---------|--------------|--------|----|--|
| 20 | 20 | 70 | 20 | 006 020 041 | 17 | 10 | |
| 25 | 25 | 88 | 17 | 006 025 041 | 25 | 10 | |
| 40 | 40 | 135 | 43 | 006 040 041 | 175 | 10 | |
| 50 | 50 | 150 | 40 | 006 050 041 | 213 | 10 | |

SNAP CLAMP

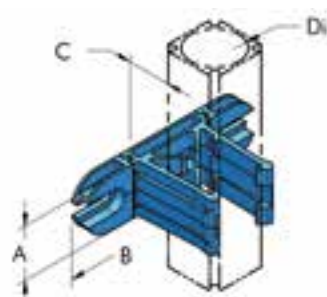

| Di mm | A mm | B mm | C mm | Part. no. | P g | n° | |
|----------|---------|---------|---------|--------------|--------|----|--|
| 20 | 20 | 70 | 20 | 006 020 042 | 17 | 10 | |
| 25 | 25 | 88 | 17 | 006 025 042 | 25 | 10 | |
| 40 | 40 | 135 | 43 | 006 040 042 | 140 | 10 | |
| 50 | 50 | 150 | 40 | 006 050 042 | 174 | 10 | |

HANGING BRACKET

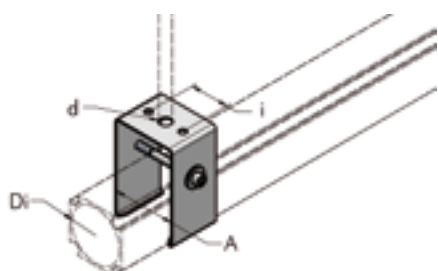



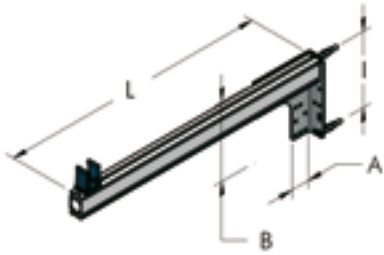

| Di mm | A mm | d mm | i mm | Part. no. | P g | n° | |
|----------|---------|---------|---------|--------------|--------|----|--|
| 32 | 36 | 11 | 24 | 006 032 073 | 100 | 10 | |
| 40 | 45 | 11 | 30 | 006 040 073 | 274 | 10 | |
| 50 | 55 | 11 | 36 | 006 050 073 | 302 | 10 | |
| 63 | 69 | 11 | 36 | 006 063 073 | 323 | 10 | |

SUPPORT BRACKET, COMPLETE

POW



| A mm | B mm | L mm | I mm | Part. no. | P g | n° | |
|---------|---------|---------|---------|--------------|--------|----|---|
| 136 | 174 | 600 | 140 | 006 020 070 | 1300 | 10 |  |
| 136 | 174 | 600 | 140 | 006 025 070 | 1300 | 10 |  |
| 136 | 174 | 600 | 140 | 006 040 070 | 1400 | 10 |  |
| 136 | 174 | 600 | 140 | 006 050 070 | 1450 | 10 |  |
| 136 | 174 | 600 | 140 | 006 063 070 | 1400 | 10 |  |

L PLATE IN GALVANIZED STEEL

POW

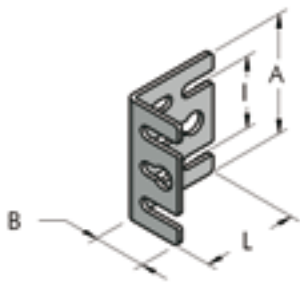

| A mm | B mm | I mm | L mm | Part. no. | P g | n° | |
|---------|---------|---------|---------|--------------|--------|----|--|
| 50 | 25 | 30 | 40 | 732 020 050 | 37 | 10 | |
| 66 | 35 | 50 | 47 | 732 066 080 | 60 | 10 | |

DRILLING JIG FOR AP22-AP28-AP45-AP54

POW

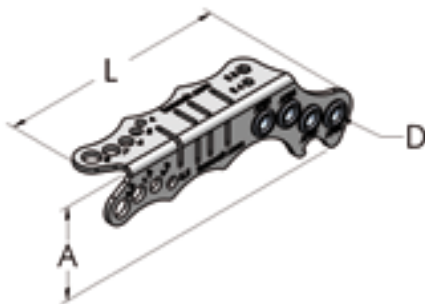

| A mm | D mm | L mm | Part. no. | P g | n° | |
|---------|---------|---------|--------------|--------|----|--|
| 45 | 6 | 136 | 911 020 050 | 90 | 1 | |

MINI COMPRESSED AIR SYSTEM AP22 - 10m

| A mm | B mm | L m | Part. no. | P kg | n° | |
|---------|---------|--------|--------------|---------|----|---|
| 125 | 125 | 2 | 006 022 102 | 5,6 | 1 |  |

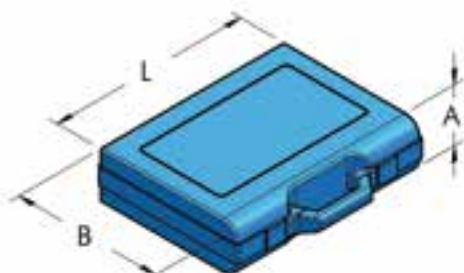
BASIC TOOLS BOX

| A mm | B mm | L mm | Part. no. | P g | n° | |
|---------|---------|---------|--------------|--------|----|---|
| 50 | 190 | 240 | 006 020 092 | 600 | 1 |  |

DEMO SUIT-CASE

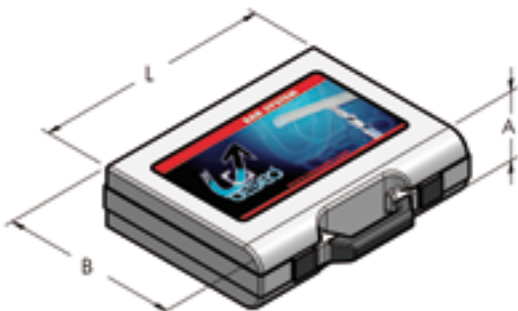

| A mm | B mm | L mm | Part. no. | P g | n° | |
|---------|---------|---------|--------------|--------|----|--|
| 80 | 340 | 440 | 006 020 090 | 3700 | 1 | |

MINI-DEMO SUIT CASE

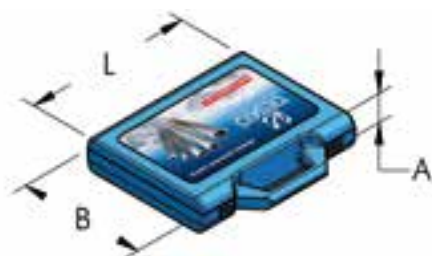

| A mm | B mm | L mm | Part. no. | P g | n° | |
|---------|---------|---------|--------------|--------|----|--|
| 50 | 190 | 240 | 006 020 091 | 550 | 1 | |

BLUE PVC STRIP

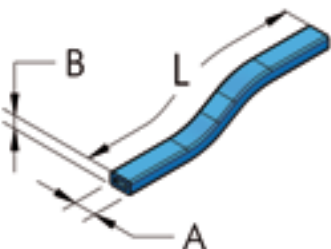

| AP | L m | A mm | B mm | Part. no. | P g | n° | |
|-------|--------|---------|---------|--------------|--------|-----|--|
| 45/54 | 1 | 10 | 5,8 | 874 010 100 | 58 | 100 | |
| 68 | 1 | 21 | 4,6 | 874 021 100 | 116 | 100 | |

VASELINE GREASE

POW



| Part. no. | P g | n° | |
|--------------|--------|----|--|
| 111 003 100 | 850 | 20 | |
| 111 003 010 | 100 | 20 | |

PTFE BLUE GREASE

POW



| Part. no. | P g | n° | |
|--------------|--------|----|--|
| 114 003 005 | 50 | 20 | |

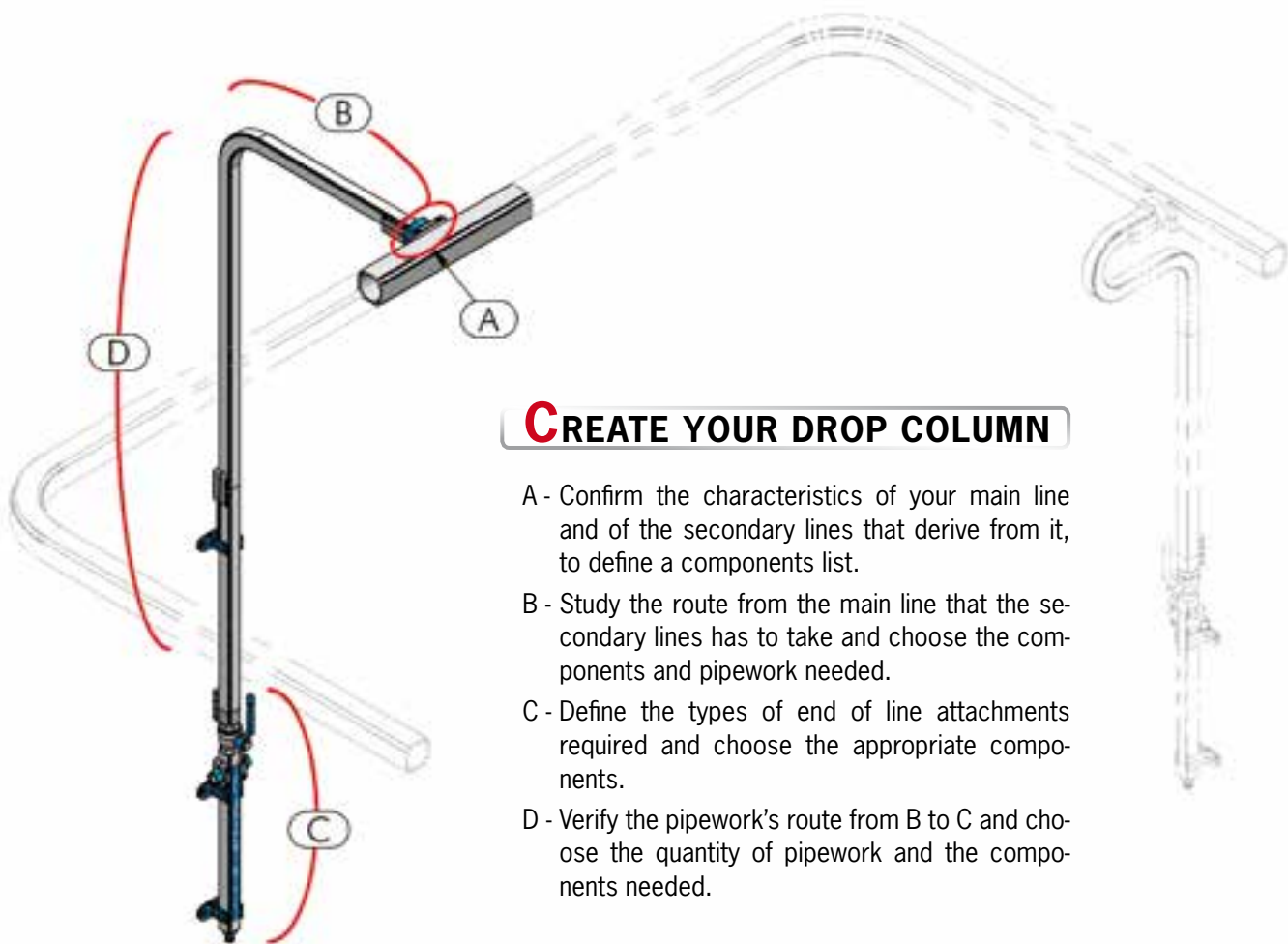

CREATE YOUR DROP COLUMN



- A - Confirm the characteristics of your main line and of the secondary lines that derive from it, to define a components list.
- B - Study the route from the main line that the secondary lines has to take and choose the components and pipework needed.
- C - Define the types of end of line attachments required and choose the appropriate components.
- D - Verify the pipework's route from B to C and choose the quantity of pipework and the components needed.

| | |
|---|----------------------------|
| A | pages 47-48-49-55 |
| B | pages 44-45-49-55-56 |
| C | pages 44-45-46-47-48-50-55 |
| D | pages 44-45 |

REDUCTION PLATE HBS - AP, COMPLETE

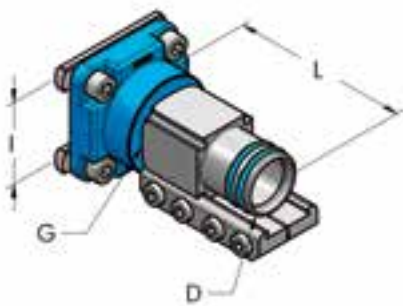
HBS



| D mm | G | I mm | L mm | Part. no. | P g | n° | |
|---------|-------------|---------|---------|--------------|--------|----|---|
| 20 | 1/2" - BSP | 36 | 49 | 006 020 037 | 180 | 1 | |
| 20 | 1/2" - BSP | 60 | 54 | 006 020 038 | 190 | 1 | |
| 25 | 3/4" - BSP | 36 | 49 | 006 025 037 | 310 | 1 | |
| 25 | 3/4" - BSP | 60 | 54 | 006 025 038 | 340 | 1 | |
| 32 | 1" - BSP | 36 | 37 | 006 032 037 | 305 | 1 |  |
| 32 | 1" - BSP | 60 | 42 | 006 032 038 | 435 | 1 |  |
| 40 | 1"1/4 - BSP | 60 | 70 | 006 040 060 | 750 | 1 |  |
| 50 | 1"1/2 - BSP | 60 | 105 | 006 050 037 | 820 | 1 | |
| 63 | - | 60 | 72 | 006 063 037 | 800 | 1 | |

2 OUTLETS BLOCK FOR AP DROP COLUMN

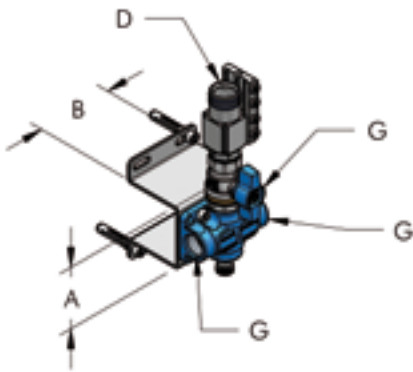

| D mm | G | A mm | B mm | Part. no. | P g | n° | |
|---------|------------|---------|---------|--------------|--------|----|--|
| 20 | 1/2" - BSP | 60 | 75 | 006 020 068 | 783 | 10 | |
| 20 | 1/2" - NPT | 60 | 75 | 006 020 468* | 783 | 10 | |
| 25 | 1/2" - BSP | 60 | 75 | 006 025 068 | 865 | 10 | |
| 25 | 1/2" - NPT | 60 | 75 | 006 025 468* | 865 | 10 | |

*G 1/4" - NPT, without condensate drain

BENT PIPE FOR AP DROP COLUMN



| Di mm | A mm | L mm | Part. no. | P g | n° | |
|----------|---------|---------|--------------|--------|----|--|
| 20 | 40 | 500 | 804 020 040 | 257 | 10 | |
| 25 | 42 | 500 | 804 025 040 | 412 | 10 | |



2 OUTLETS BLOCK FOR AP DROP COLUMN WITH BENT PIPE





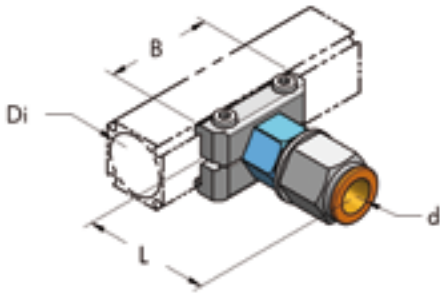





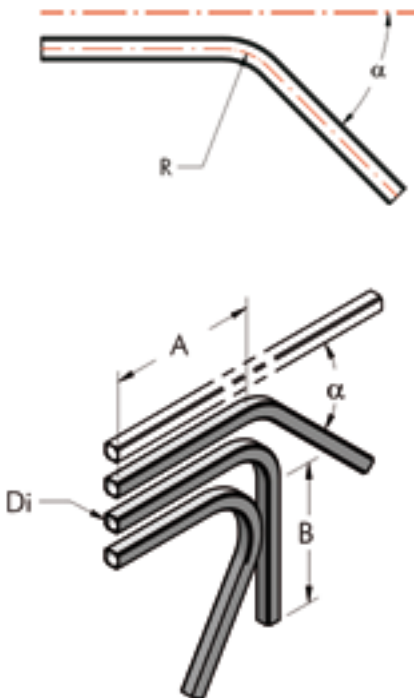

















| Di mm | G | A mm | B mm | L mm | Part. no. | P kg | n° | |
|----------|------------|---------|---------|---------|--------------|---------|----|--|
| 20 | 1/2" - BSP | 60 | 75 | 635 | 006 020 069 | 1,12 | 10 | |
| 20 | 1/2" - NPT | 60 | 75 | 635 | 006 020 469* | 1,12 | 10 | |
| 25 | 1/2" - BSP | 60 | 75 | 635 | 006 025 069 | 1,36 | 10 | |
| 25 | 1/2" - NPT | 60 | 75 | 635 | 006 025 469* | 1,36 | 10 | |

*G 1/4" - NPT, without condensate drain

OUTLET PLATE WITH D14 QUICKFIT, COMPLETE

| Di mm | d mm | B mm | L mm | Part. no. | P g | n° |  |
|----------|---------|---------|---------|--------------|--------|----|---|
| 20 | 14 | 46 | 51 | 006 020 134 | 95 | 20 | |
| 25 | 14 | 56 | 52 | 006 025 134 | 100 | 20 | |
| 32 | 14 | 50 | 44 | 006 032 134 | 120 | 20 |  |
| 40 | 14 | 70 | 50 | 006 040 134 | 190 | 20 | |
| 50/63 | 14 | 74 | 50 | 006 050 134 | 240 | 20 | |

SPECIAL ANGLE CURVED PIPE**POW**

| Di mm | A mm | B mm | R mm | α° | Part. no. | P Kg | n° |  |
|----------|---------|---------|---------|----------------|--------------|---------|----|---|
| 20 | 220 | 240 | 77 | 30 | 804 020 047 | 0,2 | 5 |  |
| 20 | 220 | 220 | 77 | 45 | 804 020 048 | 0,2 | 5 |  |
| 20 | 220 | 200 | 77 | 60 | 804 020 049 | 0,2 | 5 |  |
| 20 | 160 | 180 | 77 | 120 | 804 020 057 | 0,2 | 5 |  |
| 20 | 160 | 160 | 77 | 135 | 804 020 058 | 0,2 | 5 |  |
| 20 | 160 | 140 | 77 | 150 | 804 020 059 | 0,2 | 5 |  |
| 25 | 220 | 240 | 77 | 30 | 804 025 047 | 0,3 | 5 |  |
| 25 | 220 | 220 | 77 | 45 | 804 025 048 | 0,3 | 5 |  |
| 25 | 220 | 200 | 77 | 60 | 804 025 049 | 0,3 | 5 |  |
| 25 | 160 | 180 | 77 | 120 | 804 025 057 | 0,3 | 5 |  |
| 25 | 160 | 160 | 77 | 135 | 804 025 058 | 0,3 | 5 |  |
| 25 | 160 | 140 | 77 | 150 | 804 025 059 | 0,3 | 5 |  |
| 32 | 160 | 260 | 150 | 30 | 804 032 047 | 0,6 | 5 |  |
| 32 | 160 | 220 | 150 | 45 | 804 032 048 | 0,6 | 5 |  |
| 32 | 160 | 180 | 150 | 60 | 804 032 049 | 0,6 | 5 |  |
| 40 | 190 | 230 | 150 | 30 | 804 040 047 | 0,7 | 5 |  |
| 40 | 190 | 190 | 150 | 45 | 804 040 048 | 0,7 | 5 |  |
| 40 | 190 | 150 | 150 | 60 | 804 040 049 | 0,7 | 5 |  |
| 50 | 160 | 260 | 150 | 30 | 804 050 047 | 1 | 5 |  |
| 50 | 160 | 220 | 150 | 45 | 804 050 048 | 1 | 5 |  |
| 50 | 160 | 180 | 150 | 60 | 804 050 049 | 1 | 5 |  |
| 63 | 250 | 450 | 250 | 30 | 804 063 047 | 1,3 | 2 |  |
| 63 | 250 | 385 | 250 | 45 | 804 063 048 | 1,3 | 2 |  |
| 63 | 250 | 320 | 250 | 60 | 804 063 049 | 1,3 | 2 |  |

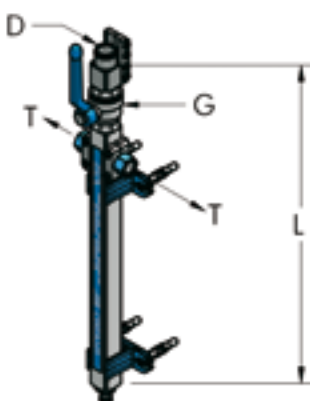
DROP COLUMN MANIFOLD COMPLETE WITH ACCESSORIES

| D mm | L mm | G | T | Part. no. | P g | n° |  |
|---------|---------|------------|------------|--------------|--------|----|---|
| 20 | 440 | 1/2" - BSP | 3/8" - BSP | 006 020 055 | 680 | 1 | |
| 25 | 440 | 3/4" - BSP | 3/8" - BSP | 006 025 055 | 1060 | 1 | |

90° CURVED PIPE

POW

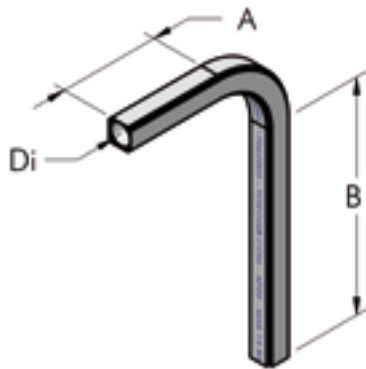

| Di mm | A mm | B mm | R mm | Part. no. | P Kg | n° | |
|----------|---------|---------|---------|--------------|---------|----|--|
| 20 | 80 | 300 | 77 | 804 020 050 | 0,2 | 5 | |
| 20 | 310 | 570 | 77 | 804 020 100 | 0,4 | 5 | |
| 20 | 370 | 2010 | 77 | 804 020 250 | 0,9 | 5 | |
| 25 | 115 | 250 | 77 | 804 025 050 | 0,3 | 5 | |
| 25 | 310 | 570 | 77 | 804 025 100 | 0,6 | 5 | |
| 25 | 370 | 2010 | 77 | 804 025 250 | 1,5 | 5 | |
| 32 | 135 | 255 | 150 | 804 032 050 | 0,8 | 5 | |
| 40 | 135 | 255 | 150 | 804 040 050 | 1 | 5 | |
| 50 | 160 | 230 | 150 | 804 050 050 | 1,05 | 5 | |
| 63 | 250 | 360 | 250 | 804 063 050 | 1,3 | 5 | |

180° CURVED PIPE

POW

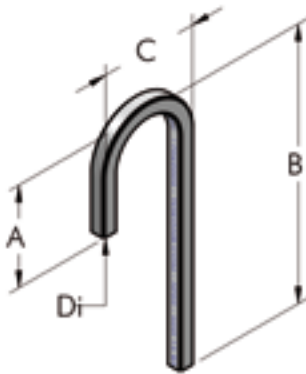

| Di mm | A mm | B mm | C mm | Part. no. | P Kg | n° | |
|----------|---------|---------|---------|--------------|---------|----|--|
| 20 | 190 | 496 | 176 | 804 020 060 | 0,25 | 5 | |
| 20 | 180 | 1255 | 176 | 804 020 149 | 0,55 | 5 | |
| 25 | 200 | 490 | 182 | 804 025 060 | 0,4 | 5 | |
| 25 | 200 | 1240 | 182 | 804 025 149 | 0,9 | 5 | |

180°-90° CURVED PIPE

POW

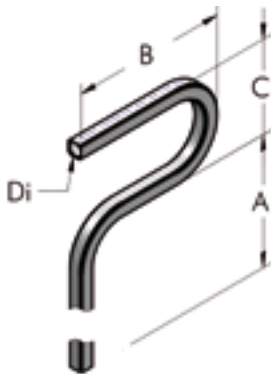

| Di mm | A mm | B mm | C mm | R mm | Part. no. | P Kg | n° | |
|----------|---------|---------|---------|---------|--------------|---------|----|--|
| 20 | 1375 | 296 | 176 | 77 | 804 020 148 | 0,95 | 5 | |
| 25 | 1370 | 302 | 182 | 77 | 804 025 148 | 1,5 | 5 | |

4 HOLES FEMALE OUTLET PLATE, COMPLETE

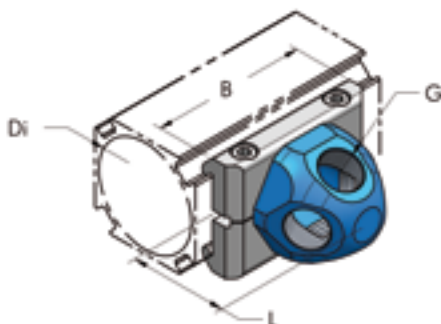

| Di mm | B mm | L mm | G | Part. no. | P g | n° | |
|----------|---------|---------|------------|--------------|--------|----|--|
| 50/63 | 74 | 47 | 3/8" - BSP | 006 050 053 | 200 | 10 | |
| 50/63 | 74 | 47 | 1/2" - BSP | 006 050 054 | 190 | 10 | |

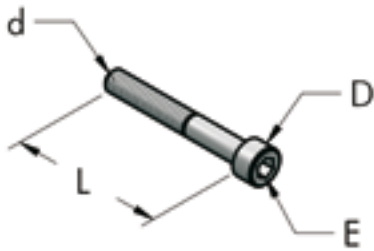
ALLEN SCREW, IN GALVANIZED STEEL

| d mm | L mm | D mm | E mm | Part. no. | P g | n° |
|---------|---------|---------|---------|--------------|--------|----|
| M5 | 20 | 8,5 | 4 | 212 005 020 | 4 | 20 |
| M5 | 25 | 8,5 | 4 | 212 005 025 | 5 | 20 |
| M5 | 30 | 8,5 | 4 | 212 005 030 | 5,5 | 20 |
| M6 | 35 | 10 | 5 | 212 006 035 | 9 | 20 |
| M6 | 45 | 10 | 5 | 212 006 045 | 14 | 20 |
| M6 | 55 | 10 | 5 | 212 006 055 | 14 | 20 |

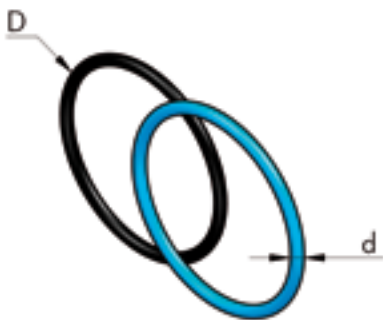
O-RING SEAL IN NBR70

| D mm | d mm | Code AS/BS NORM | Part. no. | P g | n° |
|---------|---------|--------------------|--------------|--------|-----|
| 16 | 1,78 | 2050-014 | 271 012 002 | 0,1 | 10 |
| 16 | 2 | 0120-02 | 271 013 002 | 0,2 | 100 |
| 20 | 1,78 | 2062-014 | 271 016 002 | 0,15 | 10 |
| 20 | 2 | 0160-02 | 271 017 002 | 0,2 | 100 |
| 25 | 1,78 | 2081-019 | 271 020 002 | 0,22 | 10 |
| 25 | 2 | 0210-02 | 271 021 002 | 0,8 | 100 |
| 25 | 2,62 | 3087-118 | 271 022 003 | 0,5 | 100 |
| 36 | 3 | 0300-03 | 271 031 003 | 0,9 | 100 |
| 40 | 3 | 0350-03 | 271 035 003 | 1,1 | 10 |
| 50 | 2,62 | 3175-132 | 271 044 003 | 1 | 10 |
| 50 | 3 | 0440-03 | 271 043 003 | 1,3 | 100 |

15 BAR ADHESIVE COLOUR STICKERS

HBS

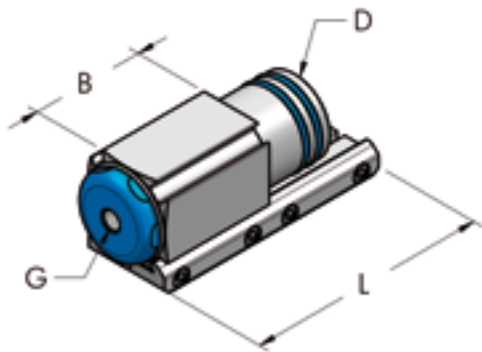

| L mm | B mm | Colour | Part. no. | P g | n° |
|---------|---------|-----------------|--------------|--------|----|
| 310 | 15 | Blue RAL 5015 | 104 015 310 | 29 | 11 |
| 310 | 15 | Green RAL 6029 | 104 015 315 | 29 | 11 |
| 310 | 15 | Brown RAL 8003 | 104 015 316 | 29 | 11 |
| 310 | 15 | Grey RAL 7000 | 104 015 317 | 29 | 11 |
| 310 | 15 | Red RAL 3020 | 104 015 318 | 29 | 11 |
| 310 | 15 | Yellow RAL 1028 | 104 015 319 | 29 | 11 |
| 310 | 28 | Blue RAL 5015 | 104 025 150 | 29 | 11 |
| 310 | 28 | Green RAL 6029 | 104 028 315 | 29 | 11 |
| 310 | 28 | Brown RAL 8003 | 104 028 316 | 29 | 11 |
| 310 | 28 | Grey RAL 7000 | 104 028 317 | 29 | 11 |
| 310 | 28 | Red RAL 3020 | 104 028 318 | 29 | 11 |
| 310 | 28 | Yellow RAL 1028 | 104 028 319 | 29 | 11 |

TERMINAL WITH NPT THREADED HOLE, COMPLETE
POW

| D mm | G | L mm | B mm | Part. no. | P g | n° | |
|---------|------------|---------|---------|--------------|--------|----|--|
| 32 | 1/4" - NPT | 46 | 30 | 006 032 425 | 200 | 10 | |
| 32 | 1/2" - NPT | 46 | 30 | 006 032 431 | 195 | 10 | |
| 40 | 1/8" - NPT | 80 | 35 | 006 040 415 | 295 | 10 | |
| 40 | 1/4" - NPT | 80 | 35 | 006 040 425 | 260 | 10 | |
| 40 | 3/8" - NPT | 80 | 35 | 006 040 416 | 290 | 10 | |
| 40 | 1/2" - NPT | 80 | 35 | 006 040 417 | 280 | 10 | |
| 40 | 3/4" - NPT | 80 | 35 | 006 040 418 | 270 | 10 | |
| 50 | 1/8" - NPT | 150 | 75 | 006 050 415 | 705 | 10 | |
| 50 | 1/4" - NPT | 150 | 75 | 006 050 425 | 700 | 10 | |
| 50 | 1/2" - NPT | 150 | 75 | 006 050 417 | 690 | 10 | |
| 50 | 3/4" - NPT | 150 | 75 | 006 050 418 | 670 | 10 | |
| 50 | 1" - NPT | 150 | 75 | 006 050 419 | 655 | 10 | |
| 63 | 1/4" - NPT | 90 | - | 006 063 425 | 660 | 10 | |

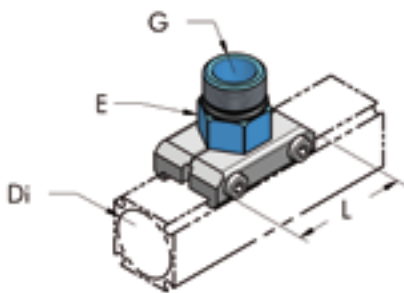
NPT MALE OUTLET PLATE, COMPLETE
POW

| Di mm | G | L mm | E mm | Part. no. | P g | n° | |
|----------|--------------|---------|---------|--------------|--------|----|--|
| 20 | 3/8" - NPT | 46 | 22 | 006 020 463 | 36 | 10 | |
| 25 | 1/2" - NPT | 46 | 22 | 006 025 464 | 49 | 10 | |
| 32 | 1/4" - NPT | 30 | 50 | 006 032 464 | 75 | 10 | |
| 32 | 3/8" - NPT | 30 | 50 | 006 032 465 | 75 | 10 | |
| 32 | 1/2" - NPT | 30 | 50 | 006 032 466 | 74 | 10 | |
| 32 | 3/4" - NPT | 30 | 50 | 006 032 467 | 72 | 10 | |
| 40 | 1/2" - NPT | 70 | 36 | 006 040 462 | 135 | 10 | |
| 40 | 3/4" - NPT | 70 | 36 | 006 040 463 | 140 | 10 | |
| 40 | 1" - NPT | 70 | 36 | 006 040 464 | 140 | 10 | |
| 50/63 | 3/4" - NPT | 74 | 50 | 006 050 463 | 190 | 10 | |
| 50/63 | 1" - NPT | 74 | 50 | 006 050 464 | 185 | 10 | |
| 50/63 | 1 1/4" - NPT | 74 | 50 | 006 050 465 | 190 | 10 | |
| 50/63 | 1 1/2" - NPT | 74 | 50 | 006 050 466 | 195 | 10 | |

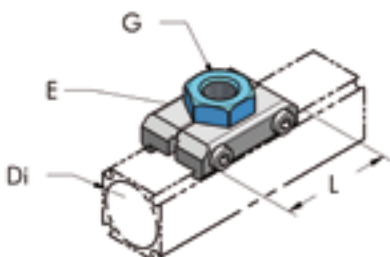



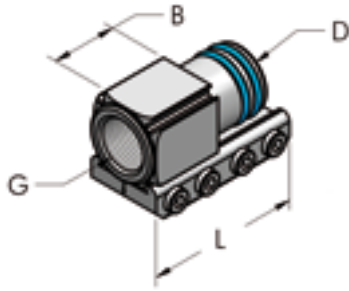

NPT FEMALE OUTLET PLATE, COMPLETE
POW

| Di mm | G | L mm | E mm | Part. no. | P g | n° | |
|----------|------------|---------|---------|--------------|--------|----|--|
| 20 | 1/4" - NPT | 46 | 22 | 006 020 433 | 36 | 10 | |
| 20 | 3/8" - NPT | 46 | 22 | 006 020 434 | 40 | 10 | |
| 25 | 1/4" - NPT | 46 | 22 | 006 025 433 | 37 | 10 | |
| 25 | 3/8" - NPT | 46 | 22 | 006 025 434 | 46 | 10 | |
| 25 | 1/2" - NPT | 46 | 30 | 006 025 435 | 55 | 10 | |
| 32 | 1/4" - NPT | 50 | 30 | 006 032 433 | 70 | 10 | |
| 32 | 3/8" - NPT | 50 | 30 | 006 032 434 | 65 | 10 | |
| 32 | 1/2" - NPT | 50 | 30 | 006 032 435 | 70 | 10 | |
| 40 | 1/8" - NPT | 70 | 36 | 006 040 432 | 148 | 10 | |
| 40 | 1/4" - NPT | 70 | 36 | 006 040 433 | 140 | 10 | |
| 40 | 3/8" - NPT | 70 | 36 | 006 040 434 | 135 | 10 | |
| 40 | 1/2" - NPT | 70 | 36 | 006 040 435 | 130 | 10 | |
| 40 | 3/4" - NPT | 70 | 36 | 006 040 436 | 120 | 10 | |
| 50/63 | 1/4" - NPT | 74 | 50 | 006 050 433 | 195 | 10 | |
| 50/63 | 1/2" - NPT | 74 | 50 | 006 050 434 | 190 | 10 | |
| 50/63 | 3/4" - NPT | 74 | 50 | 006 050 435 | 215 | 10 | |
| 50/63 | 1" - NPT | 74 | 50 | 006 050 436 | 195 | 10 | |

NPT FEMALE THREADED TERMINAL, COMPLETE

POW







| D mm | G | L mm | B mm | Part. no. | P g | n° |  |
|---------|--------------|---------|---------|--------------|--------|----|---|
| 20 | 3/8" - NPT | 46 | 24 | 006 020 428 | 54 | 10 | |
| 25 | 1/2" - NPT | 60 | 28 | 006 025 428 | 105 | 10 | |
| 32 | 1" - NPT | 46 | 23 | 006 032 427 | 205 | 10 |  |
| 40 | 1" - NPT | 80 | 35 | 006 040 427 | 260 | 10 |  |
| 50 | 1"1/4" - NPT | 150 | 75 | 006 050 427 | 615 | 10 |  |
| 50 | 1"1/2" - NPT | 150 | 75 | 006 050 428 | 565 | 10 |  |
| 63 | 1"1/2" - NPT | 90 | 20 | 006 063 428 | 430 | 10 |  |

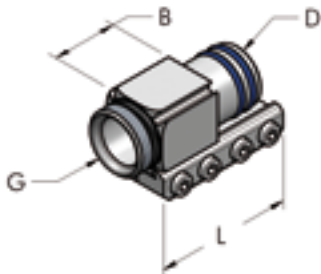



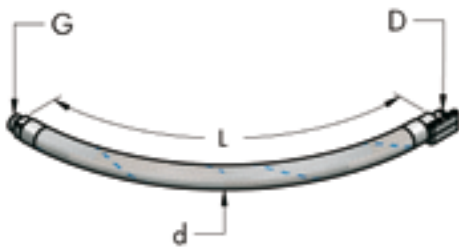

NPT MALE THREADED TERMINAL, COMPLETE

POW





| D mm | G | L mm | B mm | Part. no. | P g | n° |  |
|---------|--------------|---------|---------|--------------|--------|----|---|
| 20 | 1/2" - NPT | 46 | 24 | 006 020 430 | 57 | 10 | |
| 25 | 3/4" - NPT | 60 | 28 | 006 025 430 | 110 | 10 | |
| 32 | 1" - NPT | 46 | 11 | 006 032 430 | 200 | 10 |  |
| 32 | 1"1/4" - NPT | 46 | 13 | 006 032 429 | 255 | 10 |  |
| 40 | 1"1/4" - NPT | 80 | 35 | 006 040 429 | 245 | 10 | |
| 50 | 1"1/2" - NPT | 150 | 75 | 006 050 429 | 655 | 10 | |
| 63 | 2" - NPT | 90 | 12 | 006 063 430 | 390 | 10 |  |
| 63 | 2"1/2" - NPT | 90 | 13 | 006 063 431 | 450 | 10 |  |

FLEXIBLE PIPE WITH THREADED TERMINAL FOR CONNECTION TO COMPRESSOR FOR COMPRESSED AIR (15 BAR)

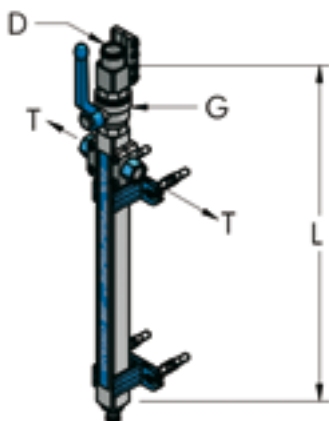
| D mm | G | L mm | d mm | Part. no. | P g | n° |  |
|---------|--------------|---------|---------|--------------|--------|----|---|
| 20 | 1/2" - NPT | 700 | 30 | 006 020 458 | 500 | 1 |  |
| 25 | 3/4" - NPT | 700 | 35 | 006 025 458 | 750 | 1 |  |
| 32 | 1"1/4" - NPT | 1000 | 44 | 006 032 458 | 2000 | 1 |  |
| 40 | 1"1/4" - NPT | 1000 | 50 | 006 040 458 | 3000 | 1 |  |
| 50 | 2" - NPT | 1000 | 65 | 006 050 458 | 4075 | 1 |  |
| 63 | 2"1/2" - NPT | 1300 | 77 | 006 063 458 | 4700 | 1 |  |

DROP COLUMN MANIFOLD WITH NPT FEMALE THREADED OUTLETS

| D mm | L mm | G | T | Part. no. | P g | n° |  |
|---------|---------|------------|------------|--------------|--------|----|---|
| 20 | 440 | 1/2" - BSP | 3/8" - NPT | 006 020 455 | 680 | 1 |  |
| 25 | 440 | 3/4" - BSP | 3/8" - NPT | 006 025 455 | 1060 | 1 |  |

MULTIFLUID 25 BAR

USE OF AP MULTIFLUID AT 25 BARS (360 PSI)

The patented AP system is suitable for inert gases and fluids.

By doubling the clamping brackets of every single joint and terminal of the system, the product can be used at a working pressure of up to 25 bar (360 psi).

The increase of the working pressure enables the transportation of incompressible fluids, such as mineral and synthetic oil, cooling and lubricating fluids.

For such a specific application a series of dedicated accessories are available, such as safety relief valves, manometers and expansion tanks, illustrated in the following pages.

Kiwa has determined that the quality management system of Teseo Srl meets the requirements of Annex III, E1 of the Pressure Equipment Directive 2014/68/UE.





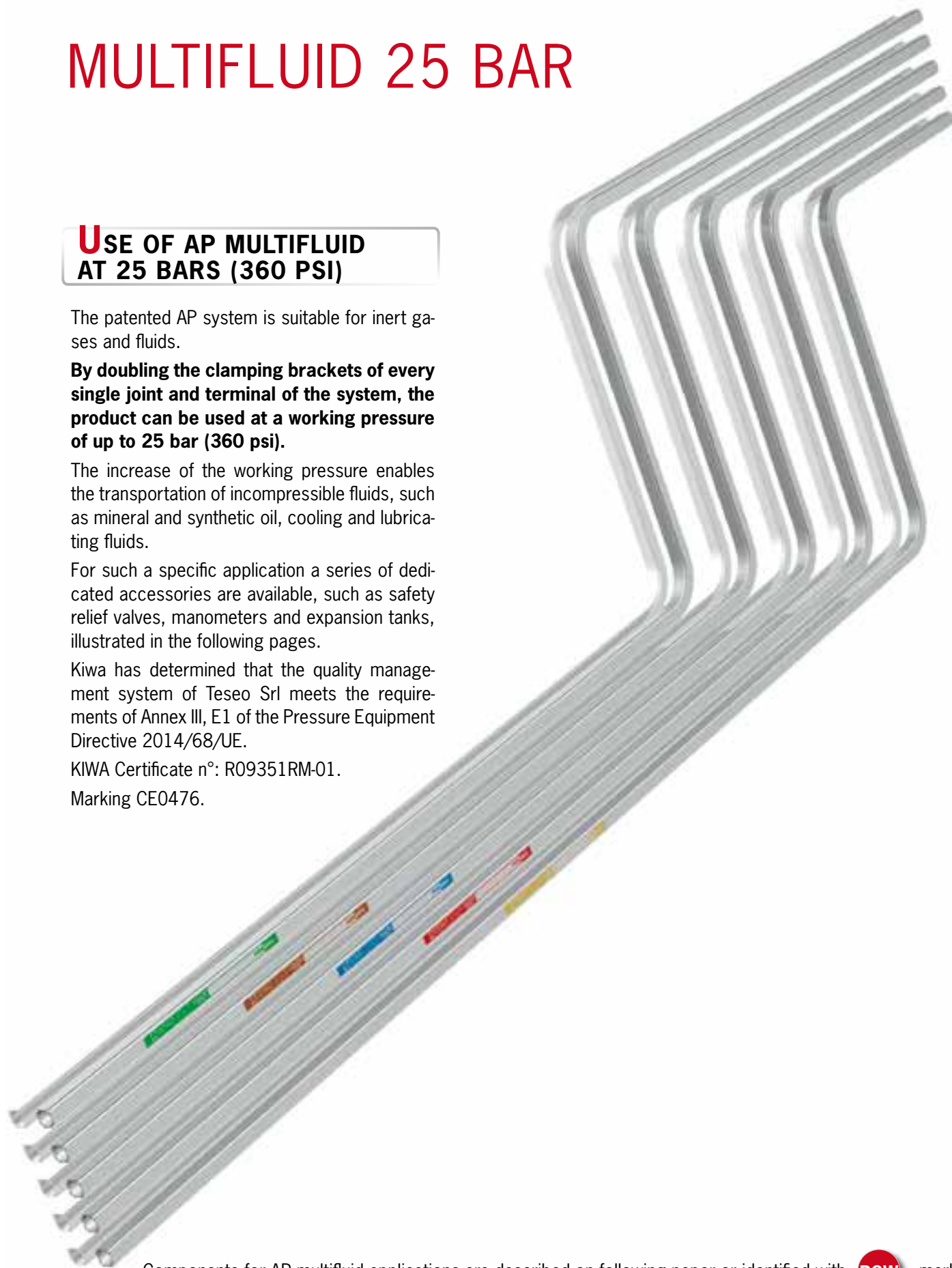

KIWA Certificate n°: R09351RM-01.

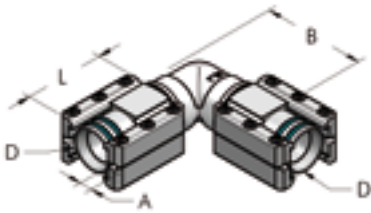
Marking CE0476.







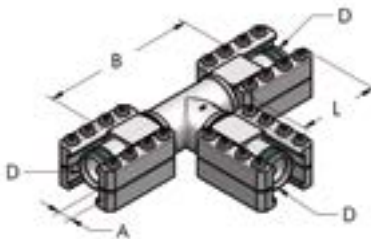

Components for AP multifluid applications are described on following paper or identified with  mark





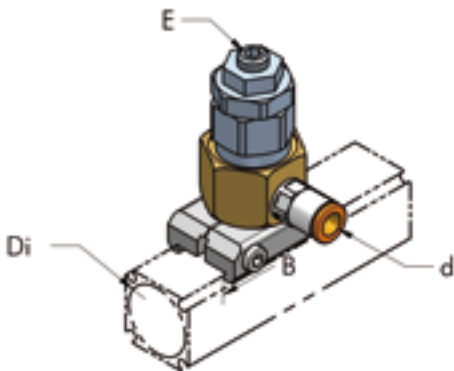

MULTIFLUID L JOINT, COMPLETE

| D mm | L mm | A mm | B mm | Part. no. | P g | n° |  |
|---------|---------|---------|---------|--------------|--------|----|---|
| 20 | 46 | 9 | 50 | 006 020 122 | 214 | 10 |  |
| 25 | 60 | 10 | 65 | 006 025 122 | 330 | 10 |  |
| 32 | 46 | 11 | 88 | 006 032 122 | 824 | 10 |  |
| 40 | 80 | 12 | 100 | 006 040 122 | 640 | 10 |  |
| 50 | 150 | 12 | 150 | 006 050 122 | 1500 | 10 |  |

MULTIFLUID T JOINT, COMPLETE

| D mm | L mm | A mm | B mm | Part. no. | P g | n° |  |
|---------|---------|---------|---------|--------------|--------|----|---|
| 20 | 46 | 9 | 100 | 006 020 124 | 270 | 10 |  |
| 25 | 60 | 10 | 130 | 006 025 124 | 425 | 10 |  |
| 32 | 46 | 11 | 120 | 006 032 124 | 1130 | 10 |  |
| 40 | 80 | 12 | 160 | 006 040 124 | 890 | 10 |  |
| 50 | 150 | 12 | 245 | 006 050 124 | 2100 | 10 |  |

OUTLET PLATE WITH PRESSURE VALVE, COMPLETE

| Di mm | d mm | B mm | E mm | Part. no. | P g | n° |  |
|----------|---------|---------|---------|--------------|--------|----|---|
| 20 | 8 | 46 | 5 | 006 020 080 | 48 | 10 |  |
| 25 | 8 | 56 | 5 | 006 025 080 | 50 | 10 |  |
| 32 | 8 | 50 | 5 | 006 032 080 | 310 | 10 |  |
| 40 | 8 | 70 | 5 | 006 040 080 | 220 | 10 |  |
| 50 | 8 | 74 | 5 | 006 050 080 | 300 | 10 |  |

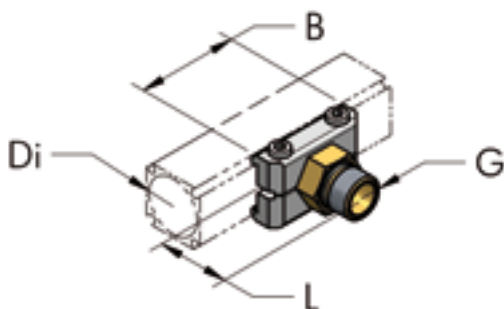
OUTLET PLATE FOR EXPANSION TANK, COMPLETE

| Di mm | G | L mm | B mm | Part. no. | P g | n° | |
|----------|---------|---------|---------|--------------|--------|----|--|
| 20 | M18x1,5 | 32 | 46 | 006 020 081 | 45 | 10 | |
| 25 | M18x1,5 | 33 | 46 | 006 025 081 | 71 | 10 | |
| 32 | M18x1,5 | 32 | 50 | 006 032 081 | 70 | 10 | |
| 40 | M18x1,5 | 36 | 70 | 006 040 081 | 136 | 10 | |
| 50/63 | M18x1,5 | 36 | 74 | 006 050 081 | 197 | 10 | |

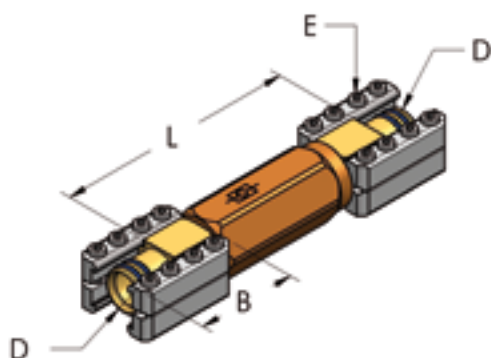



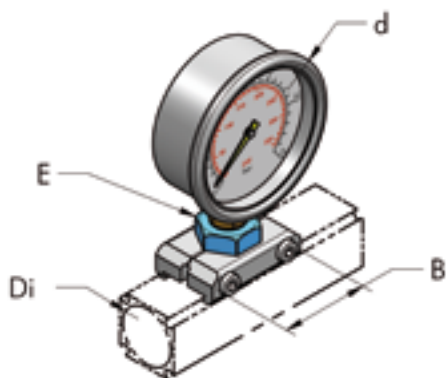

NON-RETURN VALVE, COMPLETE

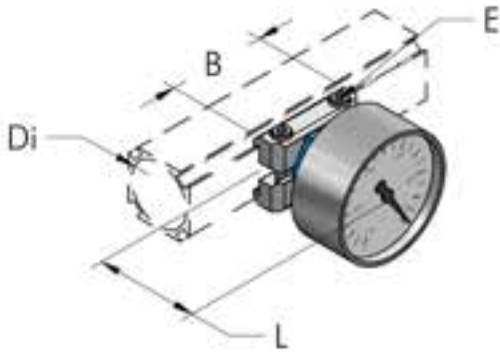
| D mm | L mm | B mm | E mm | Part. no. | P Kg | n° | |
|---------|---------|---------|---------|--------------|---------|----|--|
| 20 | 130 | 46 | 4 | 006 020 047 | 0,35 | 1 | |
| 25 | 145 | 60 | 4 | 006 025 047 | 0,82 | 1 | |
| 32 | 172 | 46 | 4 | 006 032 047 | 1 | 1 | |
| 40 | 210 | 80 | 5 | 006 040 047 | 2,2 | 1 | |
| 50 | 300 | 150 | 5 | 006 050 047 | 3,4 | 1 | |





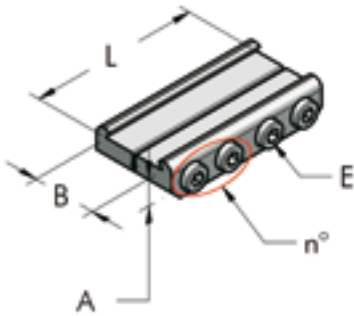

GLYCERYNE MANOMETER, COMPLETE

| Di mm | d mm | B mm | E mm | Part. no. | P g | n° | |
|----------|---------|---------|---------|--------------|--------|----|--|
| 20 | 70 | 46 | 22 | 006 020 049 | 240 | 10 | |
| 25 | 70 | 56 | 22 | 006 025 049 | 250 | 10 | |
| 32 | 70 | 50 | 30 | 006 032 049 | 275 | 10 | |
| 40 | 70 | 70 | 36 | 006 040 049 | 345 | 10 | |
| 50 | 70 | 74 | 50 | 006 050 049 | 400 | 10 | |

VACUUM MANOMETER, COMPLETE

| Di mm | L mm | E mm | B mm | Part. no. | P g | n° |  |
|----------|---------|---------|---------|--------------|--------|----|---|
| 20 | 60 | 4 | 46 | 006 020 348 | 70 | 10 |  |
| 25 | 60 | 4 | 56 | 006 025 348 | 75 | 10 |  |
| 32 | 60 | 4 | 50 | 006 032 348 | 210 | 10 |  |
| 40 | 60 | 5 | 70 | 006 040 348 | 174 | 10 |  |
| 50/63 | 60 | 5 | 74 | 006 050 348 | 230 | 10 |  |

CONNECTION CLAMP, COMPLETE

| A mm | B mm | E mm | L mm | n° | Part. no. | P g | n° |  |
|---------|---------|---------|---------|----|--------------|--------|----|---|
| 9 | 20 | 4 | 46 | 2 | 006 020 072 | 32 | 10 |  |
| 10 | 25 | 4 | 64 | 4 | 006 025 072 | 60 | 10 |  |
| 11 | 32 | 4 | 95 | 3 | 006 032 130 | 130 | 10 |  |
| 12 | 40 | 5 | 80 | 3 | 006 040 072 | 120 | 10 |  |
| 12 | 50/63 | 5 | 150 | 4 | 006 050 072 | 285 | 10 |  |

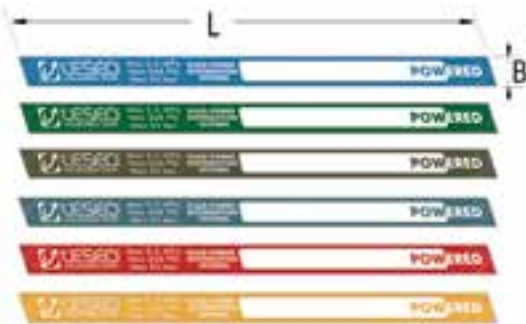
25 BAR ADHESIVE COLOUR STICKERS

| L mm | B mm | Colour | Part. no. | P g | n° |  |
|---------|---------|-----------------|--------------|--------|----|---|
| 310 | 15 | Blue RAL 5015 | 104 515 310 | 29 | 11 | |
| 310 | 15 | Green RAL 6029 | 104 515 315 | 29 | 11 | |
| 310 | 15 | Brown RAL 8003 | 104 515 316 | 29 | 11 | |
| 310 | 15 | Grey RAL 7000 | 104 515 317 | 29 | 11 | |
| 310 | 15 | Red RAL 3020 | 104 515 318 | 29 | 11 | |
| 310 | 15 | Yellow RAL 1028 | 104 515 319 | 29 | 11 | |
| 310 | 28 | Blue RAL 5015 | 104 525 150 | 29 | 11 | |
| 310 | 28 | Green RAL 6029 | 104 528 315 | 29 | 11 | |
| 310 | 28 | Brown RAL 8003 | 104 528 316 | 29 | 11 | |
| 310 | 28 | Grey RAL 7000 | 104 528 317 | 29 | 11 | |
| 310 | 28 | Red RAL 3020 | 104 528 318 | 29 | 11 | |
| 310 | 28 | Yellow RAL 1028 | 104 528 319 | 29 | 11 | |

COMPRESSED AIR AND FLUIDS PIPING SYSTEMS

AP



MODULAR MANIFOLDS INTEGRATED ON MACHINES



AP



ATS AIR TRACK SUPPLY

This unique track and trolley system is produced by Teseo srl. It has been designed to support tooling and to provide compressed air, fluids and electrical supply to any point along the track.

A.T.S. is manufactured from a modular extruded aluminium track which can be secured to a wall or any suitable structure, the trolley runs along the track with minimal effort, supporting tooling and providing power right to the point of use. Additional options can be supplied on the trolley.

The benefits are:

- no trailing hoses to impair operator movements;
- trolley allows total flexibility of use anywhere along the track;
- supported tools improve operator comfort.

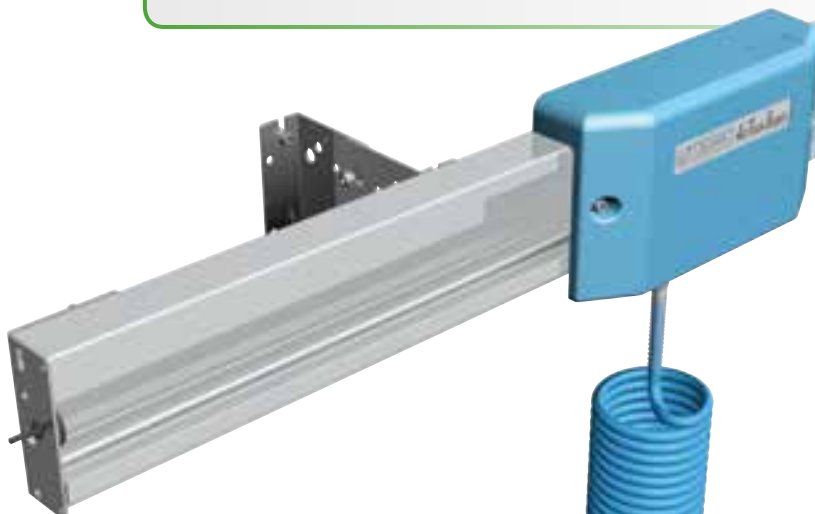

Technical specifications

- Extruded anodized aluminium rail.
- Trolley runs on roller bearings.
- Supply tube: 8 mm (1/4").
- Operating pressure: 8 bar (117 psi).
- Electric current: 240v ac
- Approximate load on trolley: 30 kg (66 lb).
- Cable: 3G-2,5 mm² C/47

The systems are delivered in a preassembled kit, packed in a stout cardboard box 3 m long (10 ft. ap-prox.) containing all its units already preassembled, along with the fixing brackets and the instructions.





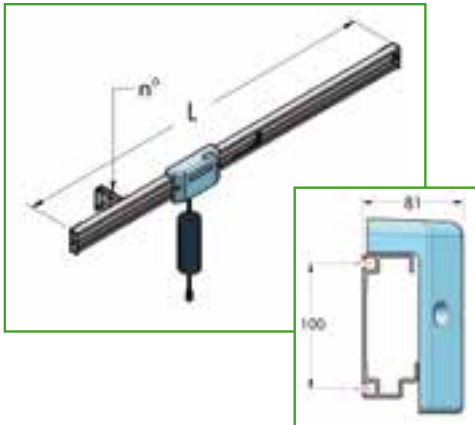

On the trolley there are one 1/4" outlet and one hook.

The following parts are to be ordered separately:

- accessories, special supports: see page 69;
- assembling tools;
- transport and installation at the customer's factory.









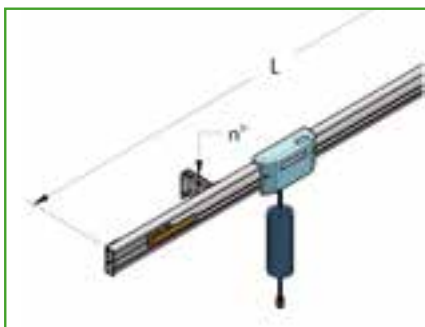







PNEUMATIC ATS, WITH CHAIN



| L m | Part. no. | Brackets n° | P Kg |  n° |  |
|--------|--------------|----------------|---------|---|---|
| 1,5 | 001 003 001 | 2 | 10 | 1 |  |
| 2 | 001 003 002 | 2 | 11 | 1 |  |
| 2,5 | 001 003 081 | 2 | 12 | 1 |  |
| 3 | 001 003 003 | 2 | 13 | 1 |  |
| 4 | 001 003 004 | 4 | 15 | 1 |  |

PNEUMATIC ATS, WITH BAR



| L m | Part. no. | Brackets n° | P Kg |  n° |  |
|--------|--------------|----------------|---------|---|---|
| 5 | 001 003 005 | 4 | 20 | 1 |  |
| 6 | 001 003 006 | 4 | 23 | 1 |  |
| 7 | 001 003 007 | 4 | 25 | 1 |  |
| 8 | 001 003 008 | 4 | 27 | 1 |  |
| 9 | 001 003 009 | 6 | 30 | 1 |  |
| 10 | 001 003 010 | 6 | 33 | 1 |  |
| 11 | 001 003 011 | 6 | 35 | 1 |  |
| 12 | 001 003 012 | 6 | 37 | 1 |  |
| 13 | 001 003 013 | 8 | 40 | 1 |  |
| 14 | 001 003 014 | 8 | 42 | 1 |  |
| 15 | 001 003 015 | 8 | 44 | 1 |  |
| 16 | 001 003 016 | 8 | 47 | 1 |  |
| 17 | 001 003 017 | 10 | 49 | 1 |  |
| 18 | 001 003 018 | 10 | 51 | 1 |  |

ATS WITH ELECTRIC FEED

This system has a compressed air feed and is equipped with a single phase electric feed. An output on the trolley is provided with a three-pole terminal board and an input on one side of the rail with a box and safety clamp. The other features are the same as the standard model.

PNEUMATIC AND ELECTRIC ATS, WITH CHAIN

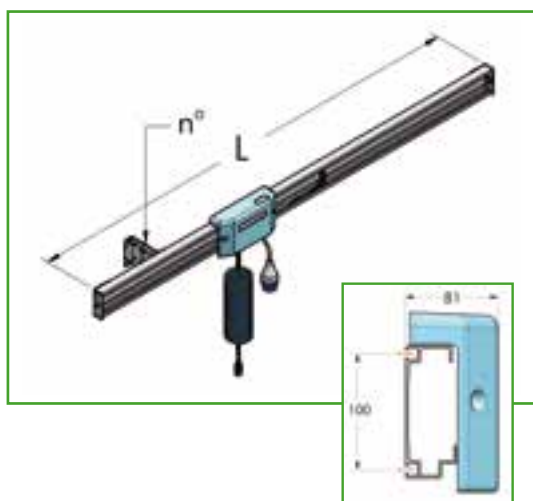

| L m | Part. no. | Brackets n° | P Kg | n° | |
|--------|--------------|----------------|---------|----|--|
| 1,5 | 001 004 001 | 2 | 13 | 1 | |
| 2 | 001 004 002 | 2 | 14 | 1 | |
| 2,5 | 001 004 081 | 2 | 15 | 1 | |
| 3 | 001 004 003 | 2 | 16 | 1 | |
| 4 | 001 004 004 | 4 | 18 | 1 | |

PNEUMATIC AND ELECTRIC ATS, WITH BAR

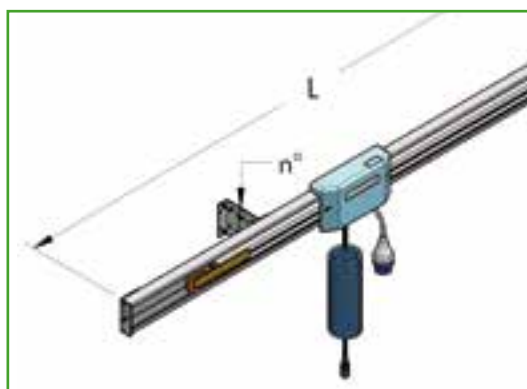

| L m | Part. no. | Brackets n° | P Kg | n° | |
|--------|--------------|----------------|---------|----|--|
| 5 | 001 004 005 | 4 | 24 | 1 | |
| 6 | 001 004 006 | 4 | 28 | 1 | |
| 7 | 001 004 007 | 4 | 31 | 1 | |
| 8 | 001 004 008 | 4 | 34 | 1 | |
| 9 | 001 004 009 | 6 | 36 | 1 | |
| 10 | 001 004 010 | 6 | 41 | 1 | |
| 11 | 001 004 011 | 6 | 44 | 1 | |
| 12 | 001 004 012 | 6 | 46 | 1 | |

WALL OR CEILING SUPPORT

MAT

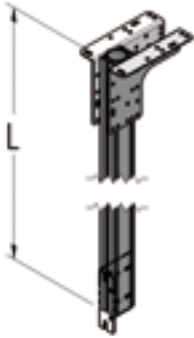

| L m | Part. no. | P Kg | n° | |
|--------|--------------|---------|----|--|
| 0,5 | 001 003 060 | 1,6 | 10 | |
| 1 | 001 003 061 | 2,5 | 10 | |
| 2 | 001 003 062 | 3,8 | 10 | |

ADDITIONAL OUTLET BLOCK



| G | Part. no. | P g | n° | |
|------------|--------------|--------|----|--|
| 1/4" - BSP | 001 003 068 | 150 | 10 | |

3 ATTACHMENT TOOLING SUPPORT

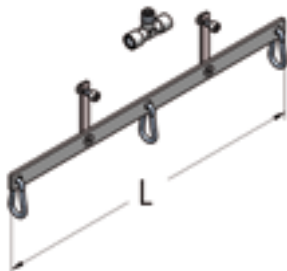

| L mm | Part. no. | P g | n° | |
|---------|--------------|--------|----|--|
| 400 | 001 003 069 | 290 | 1 | |

SPECIAL FIXING BRACKET

MAT

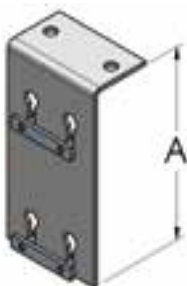

| A mm | Part. no. | P g | n° | |
|---------|--------------|--------|----|--|
| 160 | 001 005 036 | 400 | 20 | |

ADDITIONAL TROLLEY*

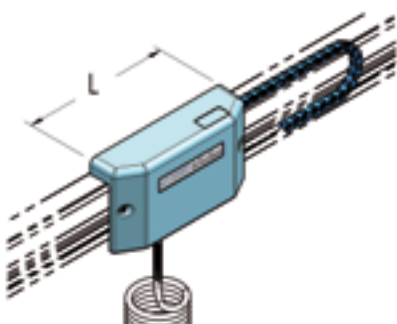

| L mm | Part. no. | P Kg | n° | |
|---------|--------------|---------|----|--|
| 270 | 001 003 067 | 1,7 | 1 | |

* Only on standard A.T.S. of 2, 3, 4 m

PLASTIC CHAIN



| L m | Part. no. | P g | n° | |
|--------|--------------|--------|----|---|
| 1 | 336 011 100 | 70 | 1 |  |

HOSE

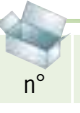

| L m | Part. no. | P g | n° | |
|--------|--------------|--------|----|---|
| 1 | 421 008 100 | 40 | 1 |  |

HOSE-CHAIN SET

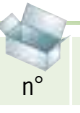

| L* m | Part. no. | P g | n° | |
|---------|--------------|--------|----|---|
| 1,5-4 | 001 002 040 | - | 1 |  |

*Specify ATS length





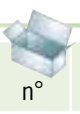

ROPE-HOSE SET









| L* m | Part. no. | P g | n° | |
|---------|--------------|--------|----|---|
| 5-18 | 001 002 024 | - | 1 |  |

*Specify ATS length



ANODIZED RAIL

| L m | Part. no. | P Kg |  n° |  |
|--------|--------------|---------|---|---|
| 1 | 801 115 100 | 1,8 | 1 |  |
| 1,5 | 801 115 150 | 2,6 | 1 |  |
| 2 | 801 115 200 | 3,5 | 1 |  |
| 2,5 | 801 115 250 | 4,4 | 1 |  |
| 3 | 801 115 300 | 5,3 | 1 |  |

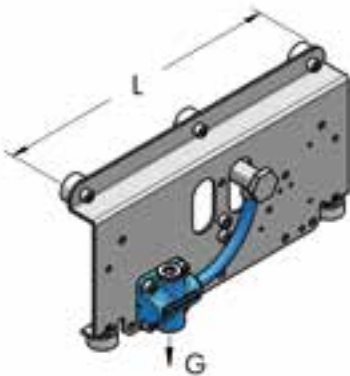

PUNCHED RAIL

| L m | Part. no. | P Kg |  n° |  |
|--------|--------------|---------|---|--|
| 1,5 | 802 115 150 | 2,6 | 1 |  |
| 2 | 802 115 200 | 3,7 | 1 |  |
| 2,5 | 802 115 250 | 4,4 | 1 |  |
| 3 | 802 115 300 | 5,3 | 1 |  |

STANDARD TROLLEY SET

| L mm | G | Part. no. | P g |  n° |  |
|---------|------------|--------------|--------|---|---|
| 270 | 1/4" - BSP | 001 003 020 | 1450 | 1 |  |

STANDARD ATS PLASTIC COVER SET

| L mm | Part. no. | P g |  n° |  |
|---------|--------------|--------|---|---|
| 270 | 001 003 022 | 185 | 1 |  |

ATS TRACK JOINT SET



| L mm | Part. no. | P g | n° | |
|---------|--------------|--------|----|---|
| 220 | 001 002 028 | 540 | 1 |  |

PULLEYS SET



| L mm | Part. no. | P g | n° | |
|---------|--------------|--------|----|---|
| 250 | 001 002 026 | 1600 | 2 |  |

ATS TRACK TERMINALS SET

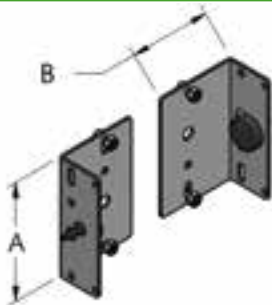

| A mm | B mm | Part. no. | P g | n° | |
|---------|---------|--------------|--------|----|---|
| 115 | 80 | 001 002 034 | 555 | 1 |  |

STANDARD FIXING BRACKETS SET

MAT



| L mm | Part. no. | P g | n° | |
|---------|--------------|--------|----|---|
| 125-135 | 001 003 036 | 550 | 1 |  |

DOUBLE JOINING PLATES SET (2)



| B mm | A mm | I mm | Part. no. | P g | n° | |
|---------|---------|---------|--------------|--------|----|---|
| 120 | 115 | 60 | 001 003 030 | 650 | 1 |  |

ATS



SAB SWINGING ARM BRACKET

The swinging arm for feeding and supporting compressed air pneumatic tools can be used over a large semi circular working area.

It consists of a horizontal bar fixed on a hollow pivot revolving on self-lubricating bearings, with gaskets for the compressed air seal.

The pivot is supported by two brackets attached to the wall with expansion dowels. For extra movement along the length of the SAB, an ATS system can be fitted.





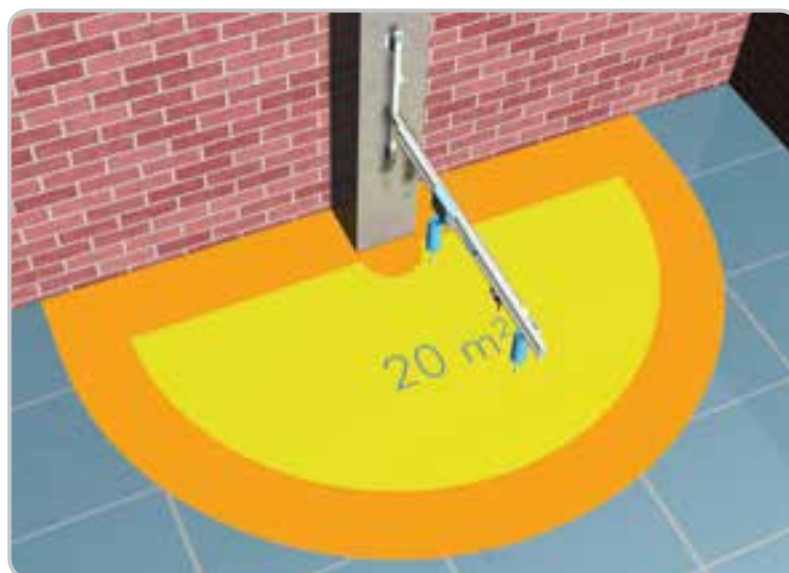

The sketch below shows an integrated solution obtained fixing a 3 m A.T.S. on a 3 m S.A.B.

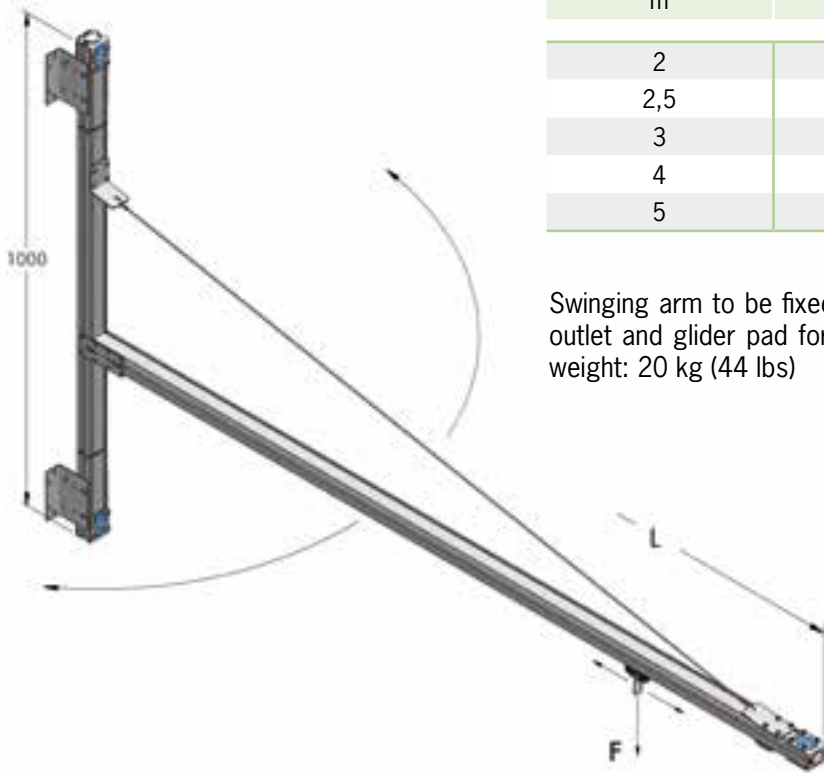
SAB



Picture above shows a 3m ATS combined with 3m SAB.



SAB - WALL VERSION

| L m | Part. no. | P Kg |  | n° |  |
|--------|--------------|---------|---|----|---|
| 2 | 002 001 200 | 11 | 1 | 1 |  |
| 2,5 | 002 001 250 | 11,5 | 1 | 1 |  |
| 3 | 002 001 300 | 12 | 1 | 1 |  |
| 4 | 002 001 400 | 13 | 1 | 1 |  |
| 5 | 002 001 500 | 14,5 | 1 | 1 |  |

Swinging arm to be fixed to the wall complete with fixing dowels, 3/8" outlet and glider pad for tool balancer attachment. Maximum bearable weight: 20 kg (44 lbs)

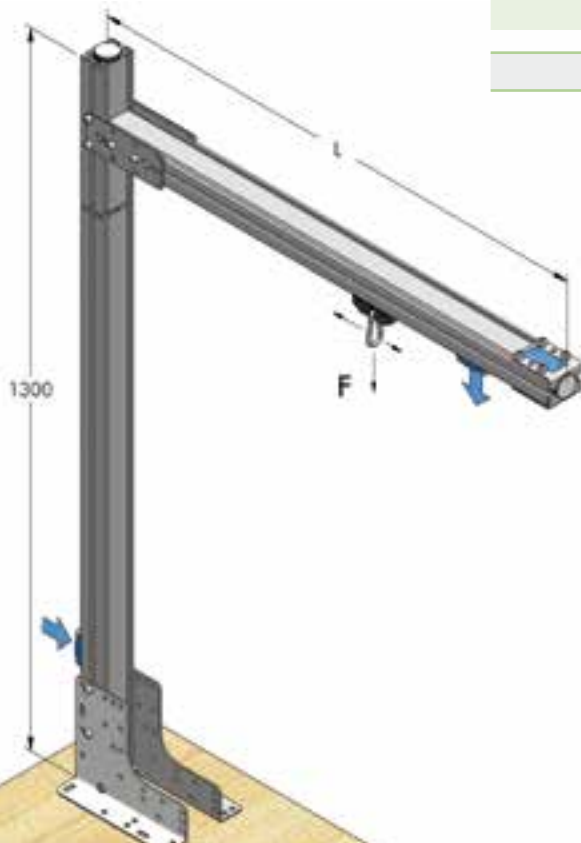
SAB

SAB - BENCH VERSION

| L m | Part. no. | P Kg |  | n° |  |
|--------|--------------|---------|---|----|---|
| 0,7 | 002 002 070 | 5,5 | 1 | 1 |  |

Swinging arm to be fixed to the bench, complete with fixing screws, 3/8" outlet plate and glider pad for tool attachment. Maximum bearable weight: 20 kg (44 lbs)

ADDITIONAL GLIDER PAD

HBS MAT



| L mm | Part. no. | P g | n° |
|---------|--------------|--------|----|
| 60 | 002 001 040 | 20 | 20 |

ADDITIONAL OUTLET PLATE

HBS MAT

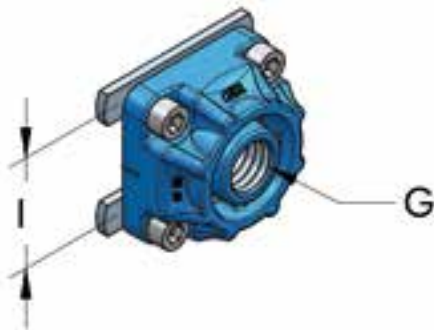

| G | I mm | Part. no. | P g | n° |
|------------|---------|--------------|--------|----|
| 3/8" - BSP | 36 | 003 001 034 | 80 | 20 |

PLATES FOR FIXING ATS ON SAB

HBS ATS



| L mm | Part. no. | P g | n° |
|---------|--------------|--------|----|
| 120 | 002 001 042 | 350 | 20 |

NYLON PIPE WITH QUICK FITTINGS

SYS



| L m | Part. no. | P g | n° |
|--------|--------------|--------|----|
| 5 | 001 003 065 | 400 | 10 |

Max operating temperature 60 °C at 8 bar

SAB INSTALLATION



SAB

WBA WORKBENCH FOR ASSEMBLY

The workbench is specially equipped for assembly work using pneumatic tools. It is constructed with a stout extruded aluminium frame which supports the A.T.S. system. The A.T.S. system consists of a rail on which a trolley runs freely. The trolley has an air outlet and a spring catch.

One of the two upright supports of the bench frame is pressurized acting as both a reservoir and a delivery tube.

To complete the system we supply height adjustable feet and cross bars with shelves to which parts bins can be hooked. The whole frame is supplied, partially assembled, in a stout cardboard box. The supply of the simple bench frame represents a valid alternative to the complete bench.

It must be fixed to the customer's existing workbench by means of proper feed.



Technical Characteristics:





- Anodized aluminium frame
- Table dimensions: 75x150 or 200 cm
- Height from ground: 85-95 cm
- Height of trolley from ground: 220 cm
- Compressed air outlet: 1/4"
- Compressed air inlet: 3/8"



WBA - WORKBENCH FOR ASSEMBLY





Complete assembly bench with A.T.S. brackets and adjustable feet. Accessories and packaging excluded.



| L m | Part. no. | P Kg |  n° |  |
|--------|--------------|---------|--|---|
| 1,5 | 004 001 150 | 77 | 1 |  |
| 2 | 004 001 200 | 87 | 1 |  |

WITH ELECTRIC FEED





As above, adding cable on trolley

| L m | Part. no. | P Kg |  n° |  |
|--------|--------------|---------|--|---|
| 1,5 | 004 003 150 | 78 | 1 |  |
| 2 | 004 003 200 | 88 | 1 |  |

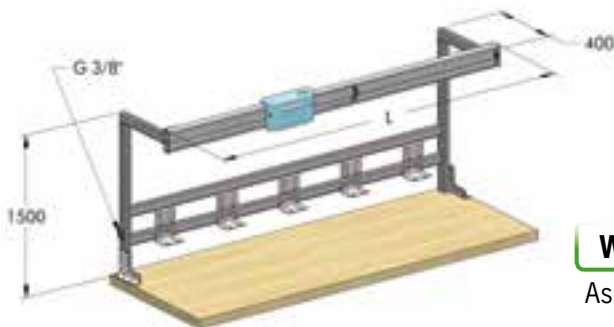
WBA - FRAME FOR BENCH





Complete frame for existing bench



| L m | Part. no. | P Kg |  n° |  |
|--------|--------------|---------|--|---|
| 1,5 | 004 011 150 | 24 | 1 |  |
| 2 | 004 011 200 | 26 | 1 |  |

WITH ELECTRIC FEED

As above, adding cable on trolley

| L m | Part. no. | P Kg |  n° |  |
|--------|--------------|---------|--|---|
| 1,5 | 004 013 150 | 25 | 1 |  |
| 2 | 004 013 200 | 27 | 1 |  |

NEON LAMP SYSTEM COMPLETE

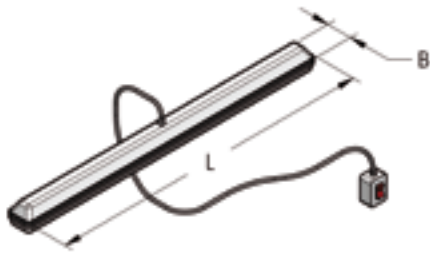

| B mm | L m | Part. no. | P Kg | n° | |
|---------|--------|--------------|---------|----|--|
| 120 | 1,30 | 004 001 072 | 3,4 | 1 | |

BLUE PVC STRIP

HBS MAT

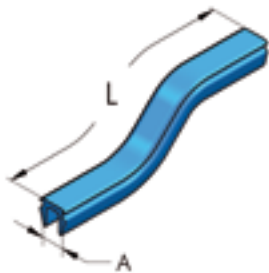

| A mm | L m | Part. no. | P g | n° | |
|---------|--------|--------------|--------|-----|--|
| 6,2 | 1 | 874 006 100 | 34 | 100 | |

RIGHT "L" PLATE

SYS

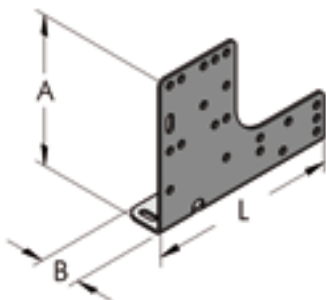

| A mm | B mm | L mm | Part. no. | P g | n° | |
|---------|---------|---------|--------------|--------|----|--|
| 130 | 36 | 174 | 732 174 130 | 400 | 20 | |

LEFT "L" PLATE

SYS

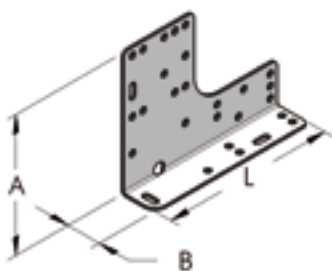

| A mm | B mm | L mm | Part. no. | P g | n° | |
|---------|---------|---------|--------------|--------|----|--|
| 130 | 36 | 174 | 732 174 131 | 400 | 20 | |

SMOOTHED PLATE

HBS SYS

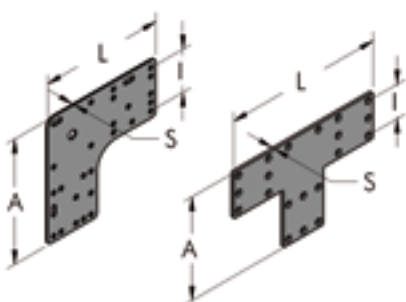

| | A mm | I mm | L mm | S mm | Part. no. | P g | n° | |
|----------|---------|---------|---------|---------|--------------|--------|----|--|
| L | 174 | 36-60 | 174 | 2,5 | 711 174 174 | 400 | 20 | |
| | 108 | 36 | 108 | 3 | 711 108 108 | 174 | 20 | |
| T | 174 | 36-60 | 268 | 2,5 | 711 174 268 | 546 | 10 | |
| | 108 | 36 | 168 | 3 | 711 108 168 | 236 | 20 | |

BRACKET

HBS

MAT

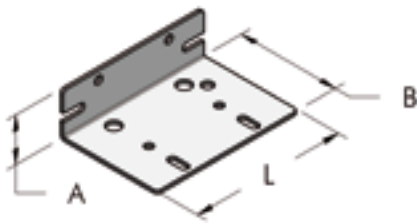

| A mm | B mm | L mm | Part. no. | P g | n° |
|---------|---------|---------|--------------|--------|----|
| 36 | 80 | 120 | 732 120 115 | 260 | 20 |

BENCH "L" PLATE

HBS

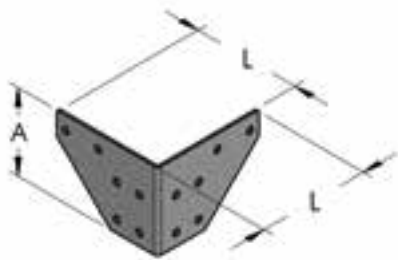

| A mm | L mm | Part. no. | P g | n° |
|---------|---------|--------------|--------|----|
| 85 | 110 | 732 085 220 | 280 | 20 |

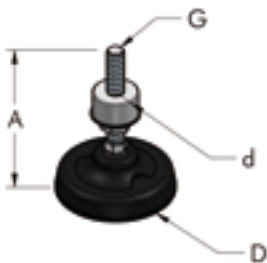
FOOT, COMPLETE

| D mm | A mm | G | d mm | Part. no. | P g | n° |
|---------|---------|-----|---------|--------------|--------|----|
| 80 | 93 | M12 | 32 | 004 001 070 | 320 | 10 |

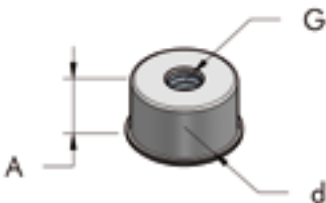
PLUG FOR FOOT

| d mm | A mm | G | Part. no. | P g | n° |
|---------|---------|-----|--------------|--------|----|
| 32 | 30 | M12 | 512 032 030 | 115 | 20 |

PVC PLASTIC COVER FOR BENCHES

| S mm | B cm | Part. no. | P kg/m ² | n° |
|---------|---------|--------------|------------------------|----|
| 2 | 200 | 151 002 200 | 2 | 2 |

SERVICE BENCH COMPLETE (IN CARDBOARD BOX, TO BE ASSEMBLED)



| A cm | B cm | L cm | Part. no. | P Kg | n° | |
|---------|---------|---------|--------------|---------|----|---|
| 90 | 75 | 150 | 004 021 150 | 30 | 1 | ↗ |
| 90 | 75 | 200 | 004 021 200 | 31 | 1 | ↗ |

CUSTOMIZED STRUCTURES

Teseo's technical department is able to design, quote and manufacture structures and work benches able to match customer's requirements. Besides supplying bespoke solutions, Teseo includes the quality and knowledge of its products.

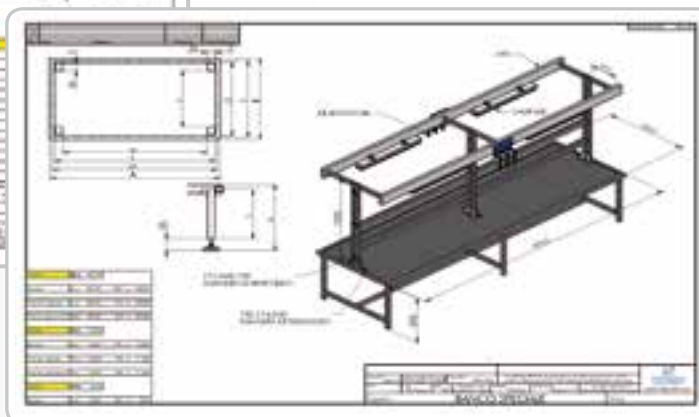
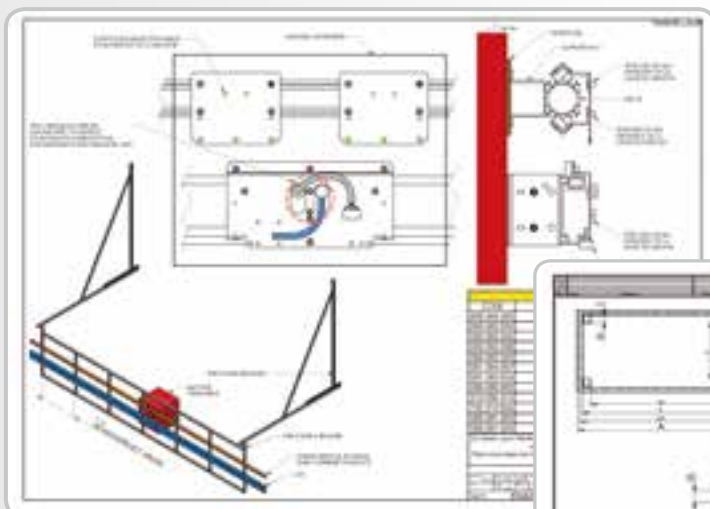
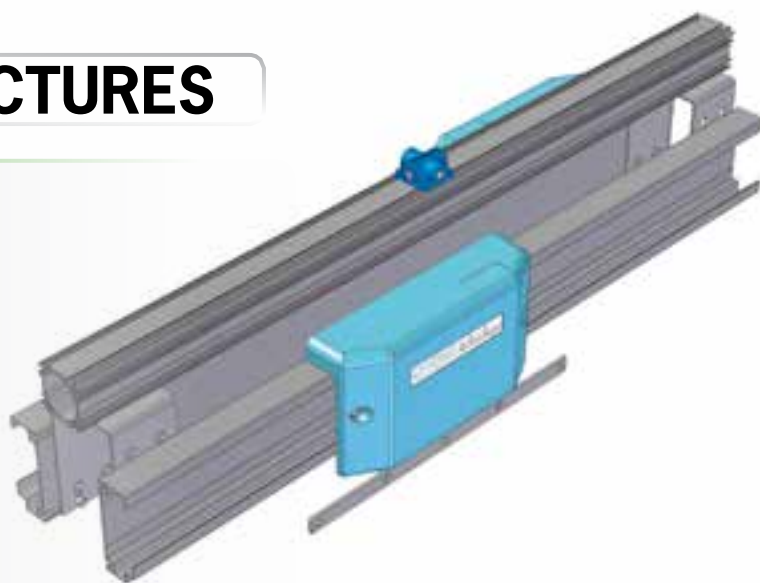

MAT MODULAR AIR TROLLEY

The trolley on hollow bar is equipped with 6 ball bearing wheels running on HBS 50 profile.

The hollow bar has a double function: track for the trolley and conduit for compressed air.

This trolley is recommended for high flow and heavy loads (max 40 kg)

Typical the application on assembly lines of car plants.

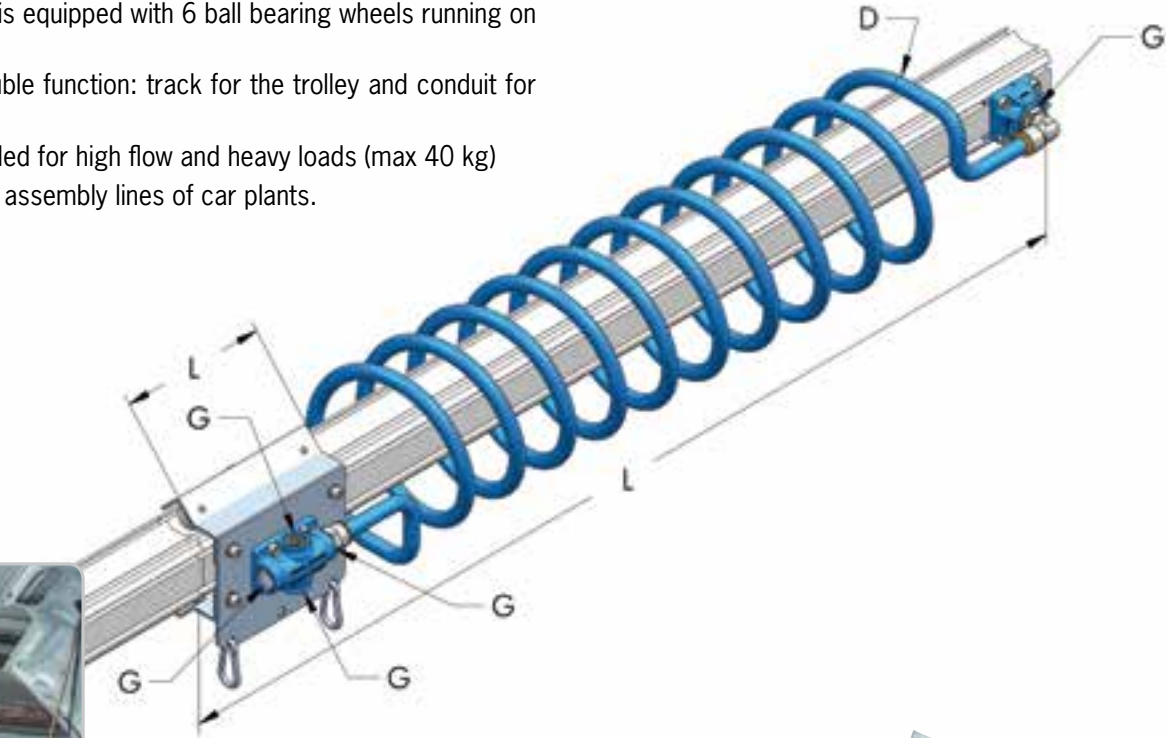

| | D mm | G | L mm | Part. no. | P g |  n° |
|-------------------|---------|------------|---------|--------------|--------|---|
| Trolley | - | 1/2" - BSP | 150 | 005 001 020 | 1400 | 1 |
| Hose | 14 | 1/2" - BSP | 4500 | 005 001 065 | 1000 | 1 |
| Hollow bar | 50 | - | 5000 | 801 060 500 | 9500 | 1 |
| Glider pad | 26 | - | 60 | 002 001 040 | 20 | 1 |



WARNING !

Maximum static load applied to the hook 30 kg ($T_{min} -20^{\circ}C$ $T_{max} +80^{\circ}C$)

HANGING SUPPORT PLATE

HBS

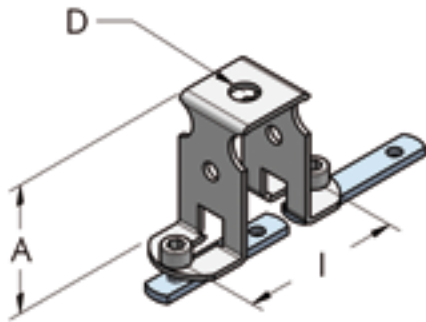

| A mm | I mm | D mm | Part. no. | P g | n° |
|---------|---------|---------|--------------|--------|----|
| 50 | 36-60 | 6,5 | 003 001 074 | 100 | 10 |

SUPPORT "L" PLATE

HBS

ATS

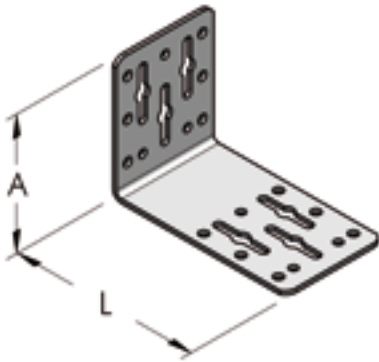

| A mm | L mm | Part. no. | P g | n° |
|---------|---------|--------------|--------|----|
| 94 | 140 | 732 078 140 | 420 | 20 |

STROKE END STOP

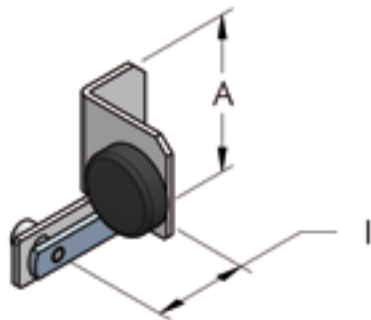

| A mm | I mm | Part. no. | P g | n° |
|---------|---------|--------------|--------|----|
| 60 | 36 | 005 001 035 | 80 | 20 |

BALL BEARING WHEEL

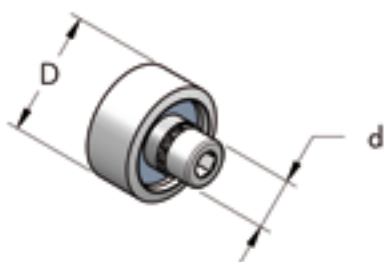

| D mm | d mm | Part. no. | P g | n° |
|---------|---------|--------------|--------|----|
| 24 | 6 | 005 001 043 | 22 | 20 |

AM ALUMINIUM MANIFOLD

AM is a revolutionary manifold for the distribution of compressed air and other fluids under pressure (drinking water, oil, inert gases and vacuum Δ).

AM is particularly suitable to be mounted onto automatic machines to feed the different servomechanisms or onto injection or die-casting presses to cool moulds.

AM is assembled by means of the Teseo HBS components and bars.

The following drawings show an example of an assembled manifold with its parts.

1

Choose the bar diameter and cut to size



2

Mark positions and sign the centres



3

Drill holes in the bar



4

Choose required outlet plates



5

Choose the appropriate terminals



6

Choose the appropriate fixing brackets



For chemical compatibility and further details contact TESEO srl technical dept.

PROPOSAL

The technical office of Teseo srl can design bespoke manifolds at the request of the customer and supply them already assembly. The manifolds can be manufactured with both systems, HBS and AP.

DT DRILLING TOOL

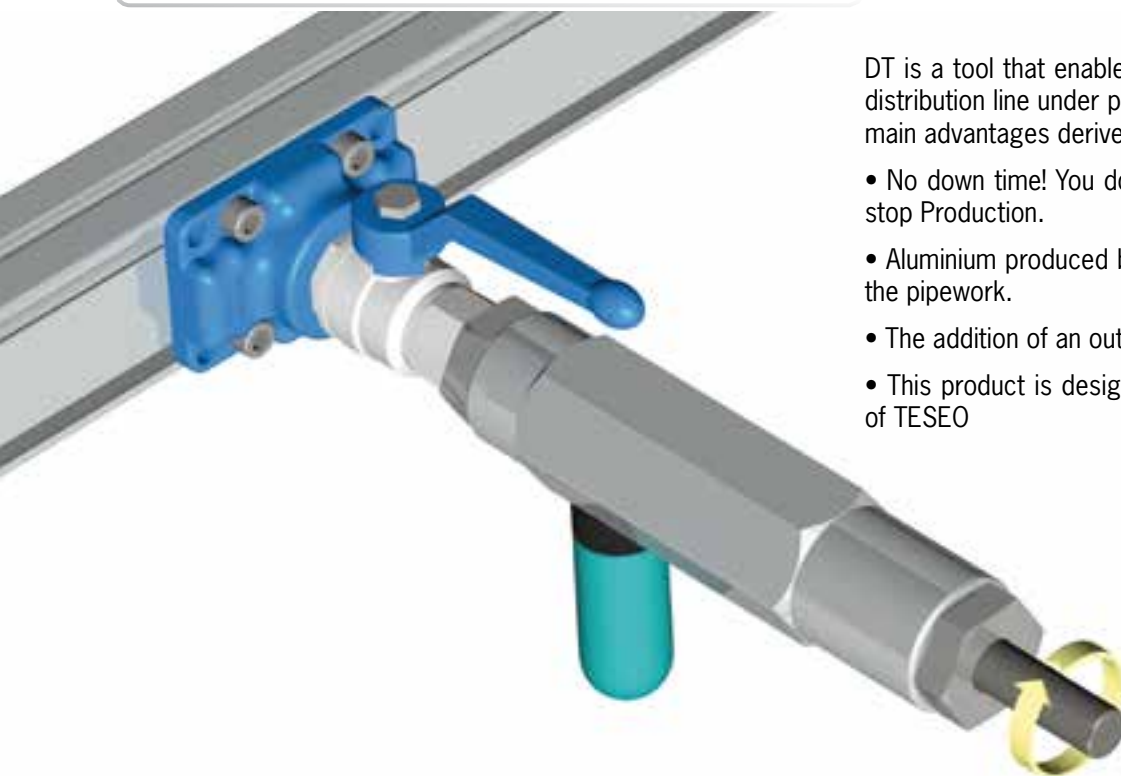



DT is a tool that enables you to drill the compressed air distribution line under pressure with ease and safety. The main advantages derived from the use of DT:

- No down time! You don't have to empty the system or stop Production.
- Aluminium produced by drilling does not penetrate into the pipework.
- The addition of an outlet plate is easy and safe
- This product is designed for the HBS and AP systems of TESEO

OUTLET PLATE

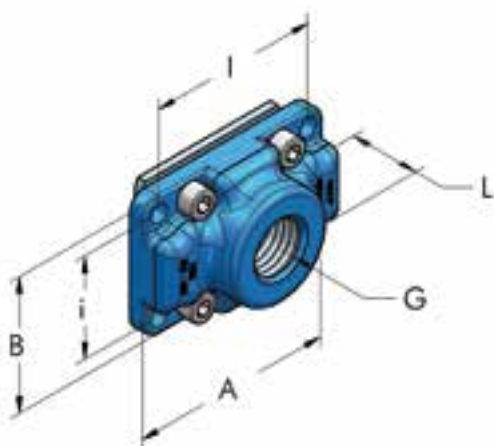
HBS



| I mm | i mm | G | A mm | B mm | L mm | Part. no. | P g |  n° |
|---------|---------|------------|---------|---------|---------|--------------|--------|---|
| 36 | 36 | 1/2" - BSP | 48 | 48 | 25 | 003 002 033 | 110 | 20 |
| 36 | 36 | 3/4" - BSP | 48 | 48 | 25 | 003 002 034 | 105 | 20 |
| 60 | 60 | 1/2" - BSP | 72 | 72 | 30 | 003 003 033 | 250 | 20 |
| 60 | 60 | 3/4" - BSP | 72 | 72 | 30 | 003 003 034 | 220 | 20 |
| 60 | 36 | 1/2" - BSP | 72 | 48 | 25 | 003 360 033 | 129 | 10 |
| 60 | 36 | 3/4" - BSP | 72 | 48 | 25 | 003 360 034 | 125 | 10 |

DRILLING TOOL

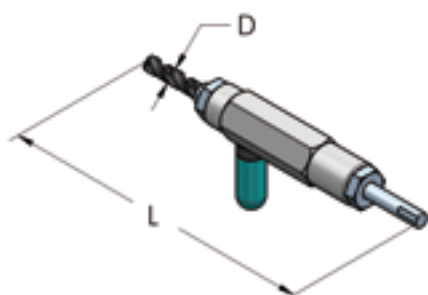

| D mm | G | L mm | Part. no. | P g |  n° |
|---------|------------|---------|--------------|--------|---|
| 13 | 1/2" - BSP | 320 | 005 004 021 | 750 | 1 |
| 19 | 3/4" - BSP | 335 | 005 004 026 | 840 | 1 |

DT

PIPE BENDER **CENT80**

We thought about a new tool that could solve quickly and economically all the bending needs in your installations.

Practical, lightweight and portable, CENT80 is the new tool that allows the manual execution of all the bends up to 180°, straight on site.

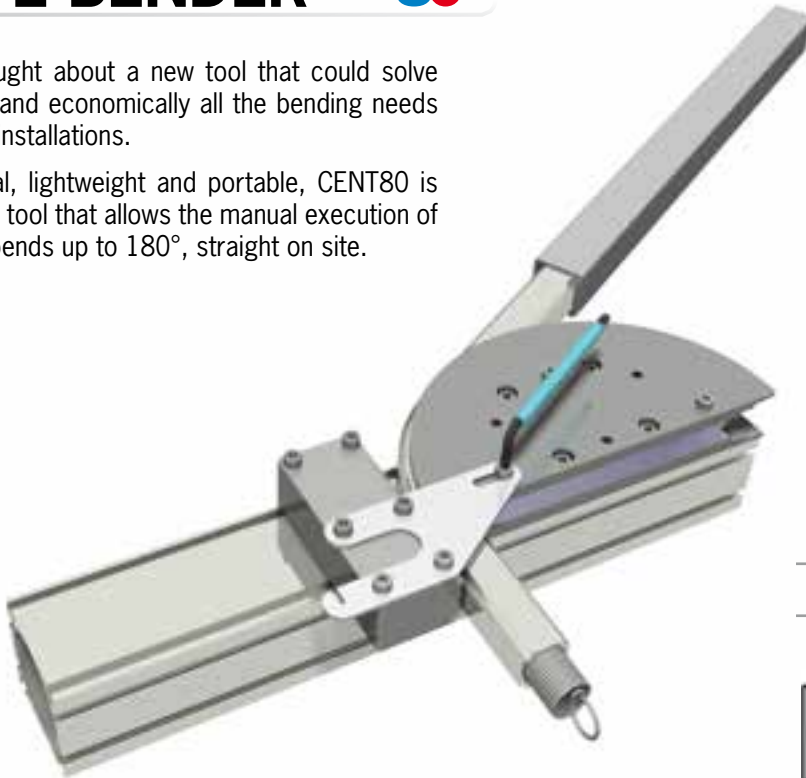

Supported products



AP28



AP22



14mm



10mm

MANUAL PIPE BENDER

AP

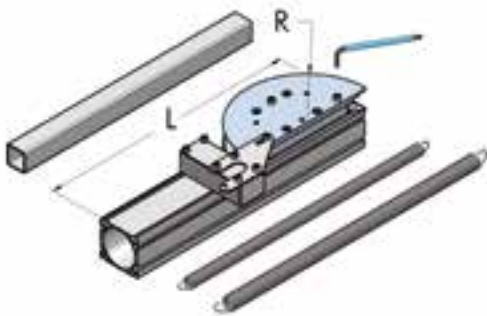

| Di mm | R mm | L mm | Part. no. |  n° |
|----------|---------|---------|--------------|--|
| 8 | 65 | 450 | 005 006 020 | 1 |
| 12 | 88 | | | |
| 20 | 100 | | | |
| 25 | 115 | | | |

CENT80 is ideal for quickly creating bends on pipework installations, anywhere you are.

On site it is possible to secure it with a robust bench vice or, with a couple of clamps, vertically on a standard bench, on the floor of the truck, on the forks of the forklift, CENT80 will follow you anywhere.



APPLICATIONS

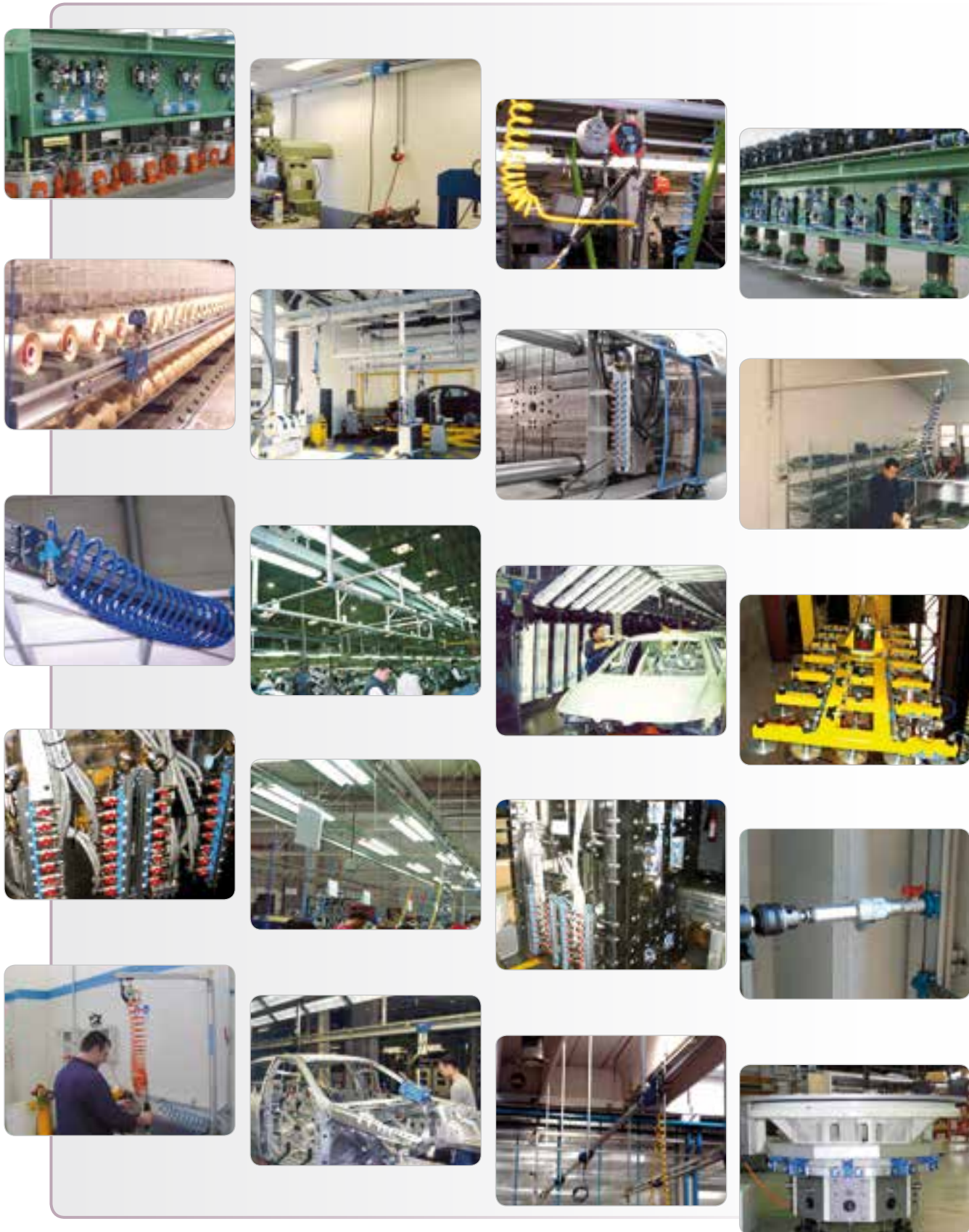



THREADED STRAIGHT PUSH FITTING

HBS

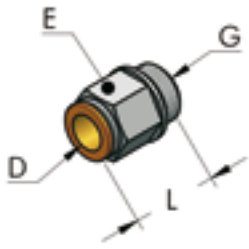
AP



| D mm | G | L mm | E mm | Part. no. | P g | n° | |
|---------|------------|---------|---------|--------------|--------|----|---|
| 14 | 3/8" - BSP | 36 | 22 | 413 017 036 | 46 | 20 |  |
| 14 | 1/2" - BSP | 34 | 22 | 413 021 034 | 47 | 20 |  |

STRAIGHT PUSH FITTING

HBS

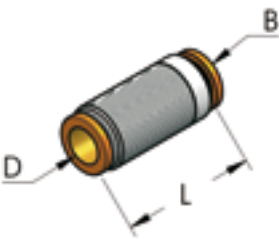



| D mm | B mm | L mm | Part. no. | P g | n° | |
|---------|---------|---------|--------------|--------|----|---|
| 14 | 20 | 48 | 413 014 048 | 62 | 20 |  |

L PUSH FITTING

HBS

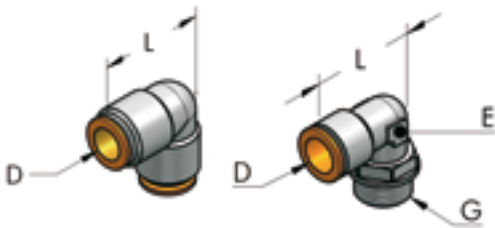
AP



| D mm | G | L mm | E mm | Part. no. | P g | n° | |
|---------|------------|---------|---------|--------------|--------|----|---|
| 14 | - | 35 | - | 414 014 035 | 77 | 20 |  |
| 14 | 1/2" - BSP | 35 | 18 | 414 021 035 | 88 | 20 |  |

T PUSH FITTING

HBS

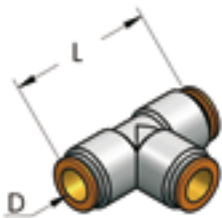



| D mm | L mm | Part. no. | P g | n° | |
|---------|---------|--------------|--------|----|---|
| 14 | 70 | 414 014 070 | 110 | 20 |  |

AIR REGULATION UNIT

SYS



| G | Configuration | Part. no. | P g | n° | |
|------------|--|--------------|--------|----|---|
| 3/8" - BSP | Pressure regulator, filter, manometer | 003 001 060 | 1200 | 10 |  |
| 3/8" - BSP | Regulator, filter, lubricator, manometer | 003 001 062 | 2000 | 10 |  |

M/F NIPPLE WITH TAPERED THREAD

SYS

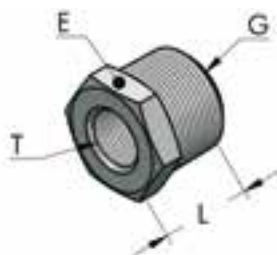

| G | T | L mm | E mm | Part. no. | P g | n° | |
|------------|------------|---------|---------|--------------|--------|----|--|
| 1/2" - BSP | 1/4" - BSP | 16 | 24 | 417 021 016 | 31 | 20 | |

THREADED PLUG, WITH SEAL

SYS

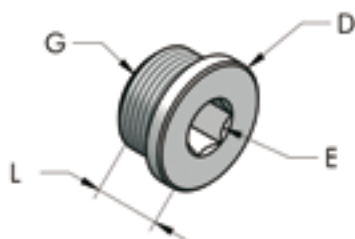

| G | D mm | L mm | E mm | Part. no. | P g | n° | |
|------------|---------|---------|---------|--------------|--------|----|--|
| 1/4" - BSP | 18 | 11 | 6 | 418 014 011 | 10 | 20 | |
| 3/8" - BSP | 21 | 13 | 8 | 418 017 013 | 20 | 20 | |
| 1/2" - BSP | 26 | 15 | 10 | 418 021 015 | 32 | 20 | |

FEMALE FLANGE EN 1092

HBS

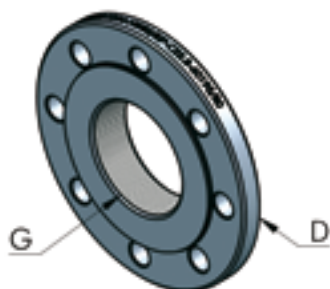

| D mm | G | holes | Part. no. | P g | n° | |
|---------|----------|-------|--------------|--------|----|--|
| 200 | 3" - BSP | 8 | 436 085 035 | 3800 | 10 | |
| 220 | 4" - BSP | 8 | 436 114 040 | 5000 | 10 | |

M/M THREADED NIPPLE

SYS

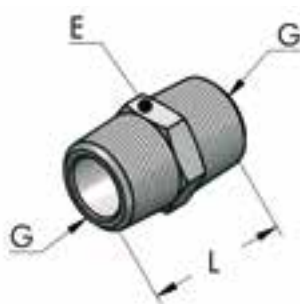

| G | L mm | E mm | Part. no. | P g | n° | |
|--------------|---------|---------|--------------|--------|----|--|
| 3/8" - BSP | 28 | 17 | 417 017 028 | 26 | 20 | |
| 1/2" - BSP | 35 | 22 | 417 021 033 | 44 | 20 | |
| 3/4" - BSP | 40 | 27 | 417 026 040 | 78 | 20 | |
| 1" - BSP | 34 | 34 | 417 033 034 | 221 | 20 | |
| 1 1/2" - BSP | 60 | 55 | 417 048 060 | 290 | 20 | |

CONDENSATE DRAIN

HBS

AP

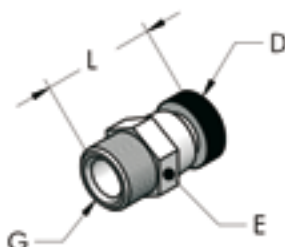







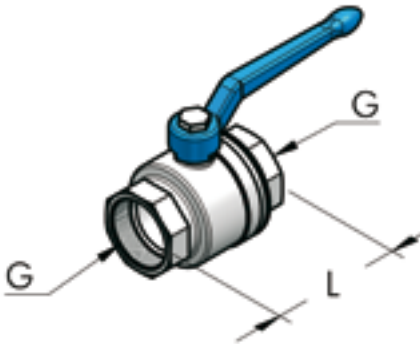

| G | D mm | L mm | E mm | Part. no. | P g | n° | |
|------------|---------|---------|---------|--------------|--------|----|--|
| 1/4" - BSP | 13 | 26 | 14 | 435 014 035 | 20 | 10 | |
| 3/8" - BSP | 14 | 27 | 17 | 435 017 024 | 30 | 10 | |

F/F BALL VALVE

HBS AP POW





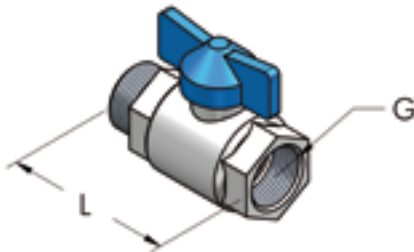

| G | L mm | Part. no. | P g | n° |  |
|-------------|---------|--------------|--------|----|---|
| 1/2" - BSP | 50 | 434 021 050 | 170 | 10 |  |
| 3/4" - BSP | 68 | 434 026 070 | 300 | 10 |  |
| 1" - BSP | 80 | 434 033 080 | 420 | 10 |  |
| 1"1/4 - BSP | 90 | 434 042 080 | 670 | 10 |  |
| 1"1/2 - BSP | 100 | 434 048 100 | 990 | 10 |  |
| 2" - BSP | 115 | 434 060 120 | 1600 | 10 |  |
| 2"1/2 - BSP | 150 | 434 075 150 | 3550 | 10 |  |

M/F BALL VALVE

HBS AP POW





| L mm | G | Part. no. | P g | n° |  |
|---------|------------|--------------|--------|----|---|
| 55 | 3/8" - BSP | 434 010 055 | 150 | 10 |  |
| 67 | 1/2" - BSP | 434 021 067 | 210 | 10 |  |
| 82 | 3/4" - BSP | 434 026 075 | 360 | 10 |  |

BALANCER FOR TOOL ATTACHMENT

ATS WBA SAB HBS





| F Kg | Part. no. | P g | n° |  |
|---------|--------------|--------|----|---|
| 0,4 ÷ 1 | 001 003 072 | 500 | 1 |  |
| 1 ÷ 2 | 001 003 073 | 500 | 1 |  |

DEBURRING TOOL

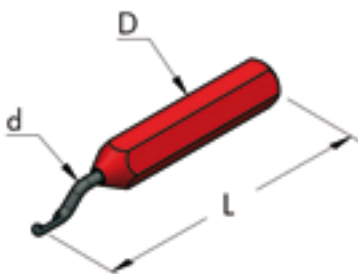
SYS





| d mm | D mm | L mm | Part. no. | P g | n° |  |
|---------|-------------|---------|--------------|--------|----|---|
| 3 | 14 | 150 | 909 012 130 | 55 | 10 |  |
| 3 | Spare blade | | 909 003 047 | 3 | 10 |  |

ALLEN SPANNER

SYS



| E mm | A mm | L mm | Part. no. | P g | n° |  |
|---------|---------|---------|--------------|--------|----|---|
| 5 | 34 | 140 | 901 130 005 | 30 | 10 |  |

ALLEN SCREW DRIVER

AP POW

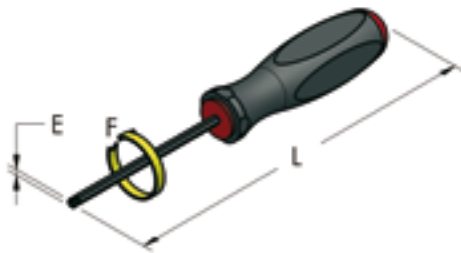

| E mm | L mm | F | Part. no. | P g | n° | |
|---------|---------|------|--------------|--------|----|--|
| 4 | 200 | 6-10 | 901 170 004 | 40 | 1 | |
| 5 | 220 | 6-14 | 901 190 005 | 75 | 1 | |

DRILLING TOOL

SYS

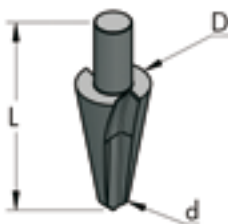

| D mm | d mm | L mm | Part. no. | P g | n° | |
|---------|---------|---------|--------------|--------|----|--|
| 20 | 8 | 62 | 922 020 062 | 46 | 1 | |

SMALL PLASTIC FOOT

HBS



| d mm | A mm | Part. no. | P g | n° | |
|---------|---------|--------------|--------|----|--|
| 25 | 20 | 293 025 022 | 8 | 20 | |
| 32 | 25 | 293 032 025 | 10 | 20 | |

SMALL WHEEL

WBA



| A mm | d mm | G | Part. no. | P g | n° | |
|---------|---------|-----|--------------|--------|----|--|
| 110 | 80 | M12 | 381 080 104 | 380 | 10 | |

HEXAGONAL NUT M6 FOR HILTI SYSTEM

SYS

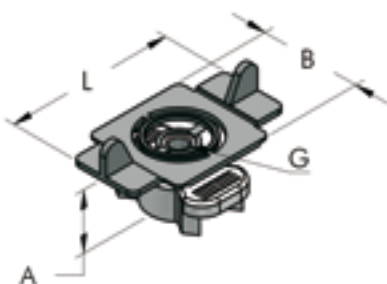



| L mm | B mm | A mm | G | Part. no. | P g | n° | |
|---------|---------|---------|----|--------------|--------|----|--|
| 50 | 30 | 15 | M6 | 233 006 034 | 22 | 50 | |

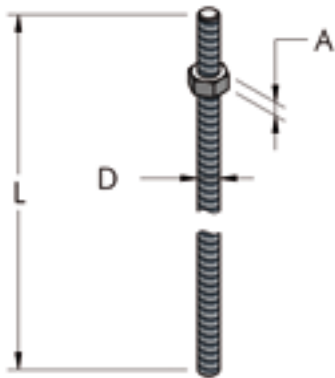

HEXAGONAL NUT

SYS



| D mm | A mm | Part. no. | P g | n° |  |
|---------|---------|--------------|--------|----|---|
| M6 | 5 | 230 006 005 | 2,5 | 20 |  |



HANGING TIE ROD

| D mm | L m | Part. no. | P g | n° |  |
|---------|--------|--------------|--------|----|---|
| M6 | 1 | 226 006 100 | 200 | 10 |  |

BUCKLE

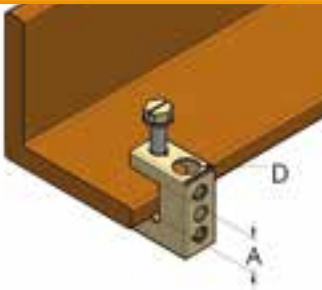
SYS





| D mm | A mm | Part. N° | P g | n° |  |
|---------|---------|-------------|--------|----|---|
| 10 | 18 | 294 010 018 | 25 | 20 |  |

SNAP CLAMP FOR ELECTRIC BUSBAR (ZUCCHINI)

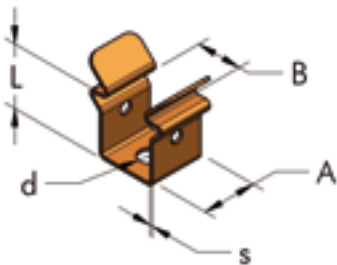
SYS





| L mm | B mm | A mm | d mm | S mm | Part. N° | P g | n° |  |
|---------|---------|---------|---------|---------|-------------|--------|----|---|
| 20 | 22 | 18 | 7,5 | 1 | 292 022 020 | 20 | 10 |  |

ALLEN SCREW 5X38

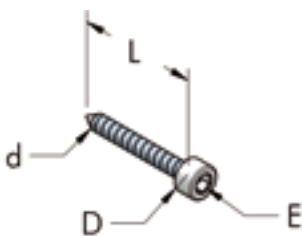
SYS





| L mm | D mm | d mm | E mm | Part. N° | P g | n° |  |
|---------|---------|---------|---------|-------------|--------|-----|---|
| 38 | 10 | 5 | 5 | 206 005 038 | 5,7 | 100 |  |

PLUG SX8

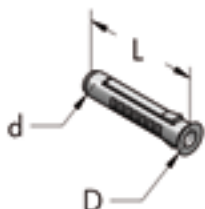
SYS



| L mm | D mm | d mm | Part. N° | P g | n° |  |
|---------|---------|---------|-------------|--------|-----|---|
| 40 | 10 | 7,6 | 208 008 040 | 1,5 | 100 |  |

TESEO PIPING SYSTEMS APPROXIMATE FLOW RATES

Based upon independent data provided by the university of Torino (I), mechanical Department, research Contract n° 1089/97.

| PRESSURE DROP | | | FLOW RATE in l/min | | | | | | | | |
|------------------------|------------------------------------|-------|--------------------|-------|----------------|----------------|--------|----------------|----------------|--------|---------|
| Working pressure (bar) | $\Delta p = P_i - P_u$ about 3% | L (m) | Ø 14 | AP22 | AP28 and HBS25 | AP36 and HBS32 | AP45 | AP54 and HBS50 | AP68 and HBS63 | HBS80 | HBS110 |
| 2 | 0,07 | 30 | 160 | 600 | 1.000 | 1.900 | 3.600 | 5.900 | 10.500 | 19.000 | 42.300 |
| 4 | 0,12 | 30 | 300 | 1.100 | 2.000 | 3.600 | 6.650 | 10.900 | 19.500 | 35.400 | 78.500 |
| 6 | 0,18 | 30 | 460 | 1.650 | 2.900 | 5.400 | 10.000 | 16.400 | 29.200 | 53.000 | 117.500 |
| 8 | 0,25 | 30 | 628 | 2.300 | 4.000 | 7.300 | 13.500 | 22.700 | 39.700 | 72.200 | 160.000 |
| 10 | 0,30 | 30 | 650 | 2.700 | 4.800 | 9.000 | 16.800 | 27.200 | 48.500 | 88.000 | 195.000 |

Flow rates in this chart are calculated with 3% pressure drop from inlet pressure. Length of pipe is 30 metres.

WE EAT THEM ALL!



Comparing nominal diameters with the competitors, the flow rate of our piping is physically larger. The blue lines are small, they fit in ours. **MAKE THE RIGHT CHOICE!**

APPROXIMATE CHART FOR CHOOSING TESEO PIPING DIAMETER - HBS SYSTEM

| Flow rate | | | LENGTH (in meters) | | | | | | | | | |
|-------------------|--------|------|--------------------|------|------|------|------|------|------|------|------|------|
| m ³ /h | l/min | cfm | 20 | 50 | 100 | 200 | 300 | 400 | 500 | 1000 | 1500 | 2000 |
| 21 | 350 | 12 | 25 | 25 | 25 | 25 | 25 | 25 | 25 | 25 | 25 | 25 |
| 30 | 500 | 18 | 25 | 25 | 25 | 25 | 25 | 25 | 25 | 25 | 25 | 25 |
| 42 | 700 | 25 | 25 | 25 | 25 | 25 | 25 | 25 | 25 | 25 | 25 | 32 |
| 54 | 900 | 32 | 25 | 25 | 25 | 25 | 25 | 25 | 25 | 25 | 32 | 32 |
| 66 | 1100 | 39 | 25 | 25 | 25 | 25 | 25 | 25 | 25 | 32 | 32 | 32 |
| 90 | 1500 | 53 | 25 | 25 | 25 | 25 | 25 | 25 | 32 | 32 | 50 | 50 |
| 120 | 2000 | 71 | 25 | 25 | 25 | 25 | 32 | 32 | 32 | 50 | 50 | 50 |
| 150 | 2500 | 88 | 25 | 25 | 25 | 32 | 32 | 32 | 50 | 50 | 50 | 50 |
| 216 | 3600 | 127 | 25 | 25 | 32 | 32 | 50 | 50 | 50 | 50 | 50 | 63 |
| 360 | 6000 | 212 | 25 | 32 | 50 | 50 | 50 | 50 | 50 | 63 | 63 | 63 |
| 540 | 9000 | 318 | 32 | 50 | 50 | 50 | 50 | 63 | 63 | 80 | 80 | 80 |
| 690 | 11500 | 406 | 32 | 50 | 50 | 50 | 63 | 63 | 63 | 80 | 80 | 80 |
| 780 | 13000 | 459 | 50 | 50 | 50 | 63 | 63 | 63 | 80 | 80 | 80 | 110 |
| 900 | 15000 | 530 | 50 | 50 | 50 | 63 | 63 | 80 | 80 | 80 | 110 | 110 |
| 1260 | 21000 | 742 | 50 | 50 | 63 | 80 | 80 | 80 | 80 | 110 | 110 | 110 |
| 1620 | 27000 | 954 | 50 | 63 | 63 | 80 | 80 | 110 | 110 | 110 | 110 | #110 |
| 2000 | 33300 | 1177 | 50 | 63 | 80 | 80 | 110 | 110 | 110 | 110 | #110 | #110 |
| 3000 | 50000 | 1766 | 63 | 80 | 80 | 110 | 110 | 110 | 110 | #110 | #110 | #110 |
| 3360 | 56000 | 1978 | 63 | 80 | 110 | 110 | 110 | 110 | #110 | #110 | #110 | #110 |
| 3720 | 62000 | 2190 | 80 | 80 | 110 | 110 | 110 | #110 | #110 | #110 | #110 | #110 |
| 4800 | 80000 | 2825 | 80 | 110 | 110 | 110 | #110 | #110 | #110 | #110 | #110 | #110 |
| 5880 | 98000 | 3461 | 80 | 110 | 110 | #110 | #110 | #110 | #110 | #110 | #110 | #110 |
| 6720 | 112000 | 3955 | 80 | 110 | #110 | #110 | #110 | #110 | #110 | #110 | #110 | #110 |
| 9600 | 160000 | 5650 | 110 | 110 | #110 | #110 | #110 | #110 | #110 | #110 | #110 | #110 |
| 12000 | 200000 | 7063 | 110 | #110 | #110 | #110 | #110 | #110 | #110 | #110 | #110 | #110 |
| 15000 | 250000 | 8829 | 110 | #110 | #110 | #110 | #110 | #110 | #110 | #110 | #110 | #110 |

This chart indicates Teseo piping diameters calculated at 8 bars pressure and 5% pressure drop from inlet pressure.
#110 = indicates pressure drop over 5%

APPROXIMATE CHART FOR CHOOSING TESEO PIPING DIAMETER - AP SYSTEM

| Flow rate | | | LENGTH (in meters) | | | | | | | | | |
|-------------------|-------|------|--------------------|-----|-----|-----|-----|-----|-----|------|------|------|
| m ³ /h | l/min | cfm | 20 | 50 | 100 | 200 | 300 | 400 | 500 | 1000 | 1500 | 2000 |
| 21 | 350 | 12 | 22 | 22 | 22 | 22 | 22 | 22 | 22 | 22 | 22 | 28 |
| 30 | 500 | 18 | 22 | 22 | 22 | 22 | 22 | 22 | 22 | 28 | 28 | 28 |
| 42 | 700 | 25 | 22 | 22 | 22 | 22 | 22 | 22 | 28 | 28 | 28 | 36 |
| 54 | 900 | 32 | 22 | 22 | 22 | 22 | 22 | 28 | 28 | 36 | 36 | 36 |
| 66 | 1100 | 39 | 22 | 22 | 22 | 22 | 28 | 28 | 28 | 36 | 36 | 36 |
| 90 | 1500 | 53 | 22 | 22 | 22 | 28 | 28 | 36 | 36 | 36 | 45 | 45 |
| 120 | 2000 | 71 | 22 | 22 | 28 | 36 | 36 | 36 | 36 | 45 | 45 | 45 |
| 150 | 2500 | 88 | 22 | 28 | 28 | 36 | 36 | 36 | 45 | 45 | 54 | 54 |
| 216 | 3600 | 127 | 28 | 28 | 36 | 45 | 45 | 45 | 45 | 54 | 54 | 68 |
| 360 | 6000 | 212 | 28 | 36 | 45 | 45 | 54 | 54 | 54 | 68 | 68 | 68 |
| 540 | 9000 | 318 | 36 | 45 | 45 | 54 | 54 | 68 | 68 | #68 | #68 | #68 |
| 690 | 11500 | 406 | 45 | 45 | 54 | 54 | 68 | 68 | 68 | #68 | #68 | #68 |
| 780 | 13000 | 459 | 45 | 45 | 54 | 68 | 68 | 68 | #68 | #68 | #68 | #68 |
| 900 | 15000 | 530 | 45 | 54 | 54 | 68 | 68 | #68 | #68 | #68 | #68 | #68 |
| 1260 | 21000 | 742 | 45 | 54 | 68 | #68 | #68 | #68 | #68 | #68 | #68 | #68 |
| 1620 | 27000 | 954 | 54 | 68 | 68 | #68 | #68 | #68 | #68 | #68 | #68 | #68 |
| 2000 | 33300 | 1177 | 54 | 68 | #68 | #68 | #68 | #68 | #68 | #68 | #68 | #68 |
| 3000 | 50000 | 1766 | 68 | #68 | #68 | #68 | #68 | #68 | #68 | #68 | #68 | #68 |
| 3360 | 56000 | 1978 | 68 | #68 | #68 | #68 | #68 | #68 | #68 | #68 | #68 | #68 |
| 3720 | 62000 | 2190 | #68 | #68 | #68 | #68 | #68 | #68 | #68 | #68 | #68 | #68 |

This chart indicates Teseo piping diameters calculated at 8 bars pressure and 5% pressure drop from inlet pressure.
#68 = indicates pressure drop over 5%

RESISTANCE TO CHEMICAL AGENTS

| MATERIAL | ALUMINIUM (Al) | O-RING SEALS | NYLON | NICKEL- PLATED BRASS | 2014/68/UE |
|----------------------------------|----------------|--------------|-------|----------------------|------------|
| GAS | | | | | |
| Compressed air | A | A | A | A | K |
| Vacuum | A | A | A | A | K |
| Nitrogen | A | A | A | A | K |
| Carbon dioxide | A | A | A | A | K |
| Argon | A | A | A | A | K |
| Argon - Nitrogen Mixture | A | A | A | A | K |
| Argon-Carbon Dioxide Mixture | A | A | A | A | K |
| Oxygen | D | C | A | A | |
| Dry Chlorine | A | D | D | C | |
| Sulphidric Acid | A | D | A | C | |
| Dry Sulphur Dioxide | A | D | C | A | |
| ORGANIC AND CHEMICAL COMPOUNDS | | | | | |
| Mineral engine oil | A | A | B | A | K |
| Synthetic motor oil | A | A | B | A | K |
| Exhausted engine oil | A | A | B | A | K |
| Oil emulsion 3% for metalworking | A | A | A | A | K |
| Oil emulsion 8% for metalworking | A | A | A | A | K |
| Glycol | A | A | B | A | K |
| Glycol and water mixture | A | A | A | A | K |
| Windscreen washing fluid | B | D | B | D | |
| Ammonia solution | A | B | B | C | |
| Methyl alcohol | B | B | B | C | |
| Vinilic glue | A | A | A | A | |
| Ethanol | A | A | B | A | K |
| Formalin | A | A | B | A | K |
| Acetone | A | D | A | A | K |
| Aniline | C | D | C | A | |
| Potassium bicarbonate | D | B | B | A | |
| Potassium permanganate | A | B | D | A | |
| Benzene | A | D | B | A | |
| Gasoline | A | B | B | A | K |
| Diesel fuel | A | A | B | A | K |
| ACIDS | | | | | |
| Citric acid | B | A | B | C | |
| Boric acid | B | A | B | C | |
| Acetic acid | B | C | D | C | |
| Cloridric acid | C | D | D | D | |
| Oleic acid | B | C | B | D | |
| Nitric acid | C | D | D | C | |
| Tartaric acid | A | A | B | C | K |
| Phosphoric acid | D | D | D | D | |
| Sulfuric acid | D | D | D | D | |

Legend: A = Very good; B = Good; C = Low; D = Poor; K= KIWA PED

Attention: the content of this table is based upon customer's inquiries forwarded by customers during past 20 years. It is always recommended to evaluate the PED 2014/68/UE directive and consider norms and laws applicable. PED = 2014/68/UE, annexe III, E1 compliant - CE 0476 - KIWA. In the eventually of any doubt, please contact Teseco's Technical Office.

CONDITIONS FOR THE TRANSPORTATION OF WATER IN THE HBS SYSTEM

The HBS product by Teseco is suitable to carry water provided that the following conditions are respected.

- Softened water is to be avoided because of its richness in sodium ions.
- The acidity must range between pH5 and pH8.
- The maximum content of chlorine ions must not exceed 2000 mg/L.
- Iron (Fe), Nickel (Ni), Lead (Pb) and Tin (Sn) must not be present.
- The maximum Copper (Cu) content should be not exceed 0,05 mg/L; the maximum Mercury (Hg) content should not exceed 0,005 mg/L.
- Aluminium must not be in direct contact with iron or Copper. Aluminium and iron must be insulated by galvanization while aluminium and Copper must be insulated with plastic or inert organic matter.
- Oxygen, Carbon Dioxide and ammonia ions, dissolved in water do not cause corrosive effects.
- Water with solution of emulsion oil for the cooling of machinery does not cause any problems.
- We recommend electrical earth bonding of our pipework systems in order to avoid any stray currents.
- We recommend the use of ANODIZED bars.

In the event of any doubt, please contact Teseco's Technical office.

Source: AQM, technical services
SINAL Accredited
(UNI CEI EN 45001).

HBS-AP ASSEMBLING INSTRUCTIONS

1. INTRODUCTION

- 1.1. This manual is very easy to consult and we recommend reading it before starting work, bearing in mind the regulations in your country.
- 1.2. Pay attention to the instructions identified by the mark **ATTENTION**.
- 1.3. The HBS and AP ranges of products from TESEO are suitable for the distribution of compressed air, nitrogen, vacuum and inert gases.
- 1.4. For any application with **water** distribution, please check our sheet on page 96. For other **fluids** it is necessary to know their exact composition and to check if they are compatible with the HBS and AP system; in case of any doubt, please contact the technical department of TESEO.
- 1.5. **ATTENTION: TESEO is not responsible for problems due to failure to follow the instructions contained in within this manual.**

2. TOOLS AND FIXTURES

- 2.1. The **tools required** to install even a small system are: one Allen wrench for 4 and 5 mm slots, one de-burring tool or one scraper, neutral grease, one drill bit and one drilling machine, one hacksaw, some small tubes for placing the small plates, one tape measure.
- 2.2. The **tools suggested** for fast and safe work are: one pair of adjustable pliers, one battery screwdriver, one drilling jig, one chop saw with metal circular blade, one stepped cone cutter or cone cutter, one PTFE tape or sealing band, one torque wrench, one level or one plumb line, one bench on wheels.
- 2.3. Close attention should be paid to safety. To this purpose, scaffolding, helmets, harnesses, gloves and protective glasses must be used by all personnel.
- 2.4. **ATTENTION: follow the regulations concerning safety at work presentlv in force in your country.**



3. PREPARATION

- 3.1. **Cutting:** this can be done by hand, using a hacksaw provided that the blade has been lubricated with vaseline or other oils, as aluminium is a material which could clog the tool. When making many cuts, we suggest using a circular chop saw with metal cutting blade.
- 3.2. **Deburring:** after cutting the pipe, it is necessary to remove the sharp edges using a de-burring tool. This operation is required to avoid any damage to the o-ring and to make easier the connection.
- 3.3. **Lubrication:** in order to make it easier to insert joint, lubricate the inner surface of the hollow bar with neutral grease (ref. page 35), in order to avoid any damage to the O ring.

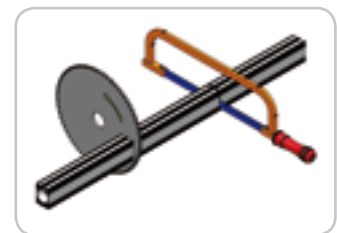

3.4. **Drilling:** during the drilling operation, it is required to have the pilot hole in the centre of the pipe. Please use a drilling jig.



The maximum diameter of the smoothed hole must not exceed the recommended diameter. Please see the table.

| HBS25 | HBS32 | HBS50 | HBS63 | HBS80 | HBS110 |
|-------|-------|-------|-------|-------|--------|
| | | | | | |
| AP22 | AP28 | AP36 | AP45 | AP54 | AP68 |
| | | | | | |

The following tools can be used: a drill, a coned drill, a counter bore, a hole saw.

3.5. **Hole de-burring:** on outlet plates we recommend de-burring a maximum 1mm around the hole in order not to damage the o ring seal.

3.6. **ATTENTION: Wear protective glasses and gloves during cutting and drilling. Flying chips could cause injury to eyes and hands.**



4. HBS SYSTEM ASSEMBLY OPERATIONS

4.1. **Insertion of small plates:** the small plates can be inserted into the slot in the bar at any point. Straighten and secure them by means of sharpened small tubes.



4.2. **Joint insertion:** to make it easier, first insert the plates and the small plates with loose screws into the slots, then insert the joint and connect the second bar. Now position the plates half-way on each side and tighten the screws.



4.3. **How to tighten the screws:** The screws must be tightened but be careful not to tear the thread. The torque of the m6 screws should be between a minimum of 10 N·m (91 inch-lbs) and a maximum of 13.5 N·m (120 inch-lbs).

4.4. **“L” and “T” Joint** have to be fixed using specific fixing plates. They allow you to fix pipes on two sides. Should you need to connect HBS 25 piping, using an “L” joint on the narrow side, it is required to cut 6 mm on each corner.



4.5. **Expansion of the line:** for lines with a straight section longer than 50 meters, we suggest mounting a sliding joint every 30 to 40 meters. This will make any future dismantling easier. The two fixing plates have to be assembled in the middle of the available space.

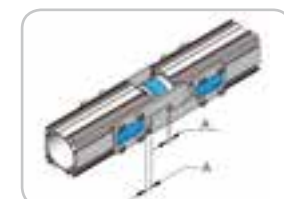

4.6. **ATTENTION: check that all the screws are tightened at the end of each pipe connection and when securing them be careful not to tear the thread.**

5. AP SYSTEM ASSEMBLY OPERATIONS

- 5.1. **Clamping brackets installation:** insert one side of the clamping bracket in the groove of the profile, push both clamping brackets to touch the profiles and tighten the screws.
- 5.2. **Joints:** introduce the joint into one pipe, then connect the second pipe, position the clamping bracket equally so that it is clamping both pipes or fitting and half the other and finally tighten the screws.
- 5.3. **Screws tightening:** Screws must be tightened properly but not excessively, to avoid stripping the threads. The recommended tightening torque for M5 screws is between 9 N·m and 11 N·m maximum. For M6 screws the minimum is 13 N·m and the maximum 15 N·m.
- 5.4. **ATTENTION:** once completed the assembly of every joint, double check the screws correct blockage and be sure that no threads are damaged for excessive tightening.



6. INSTALLATION

- 6.1. **How to trace the distribution line:** trace a horizontal line at the chosen height by means of a stretched plumb line. With the TESEO system you do not need to give the inclination to collect the condensate as the up-column and the down-column are already equipped at the bottom with a collection and a drain valve.
- 6.2. **How to secure the pipework:** The pipework can be supported by several types of ceiling or wall mounted fixing plates and brackets. The recommended distance between these fixing brackets is 2 to 4 meters, depending on the weight of the distributed fluid.

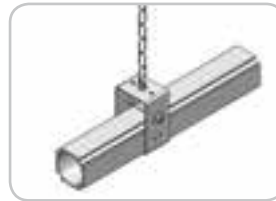
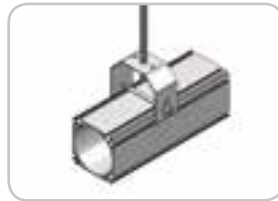
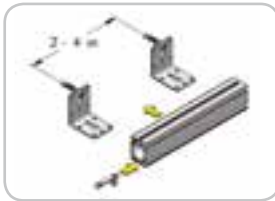

- 6.3. **Isolation valves:** ball valves must be mounted both at the beginning of the line and at the beginning of the branches of the main line. Mount a pressure gauge at the beginning of the main line and a safety valve on the air receiver.
- 6.4. **Take-offs: for the down tubes:** to prevent any impurities fouling the bottom of the hollow bar, we recommend fitting the outlet plates on the sides of the hollow bar.
- 6.5. **Flexible pipe:** its use is recommended in order to isolate the installation from the vibrations of the compressor.
- 6.6. **Earthing:** it is recommended in case of stray electrical currents.
- 6.7. **ATTENTION:** wear a safety helmet, harnesses and use scaffolding in compliance with the law before tracing and installing the line, as these operations are usually carried out at a dangerous height.



7. GENERAL TEST AND INSPECTION

- 7.1. **Inspect** every part of the system and check that no screw is loose, that all joints are properly in place and all brackets are properly secured.
- 7.2. Check that the **service valve** placed between the compressor room and the line is closed.
- 7.3. Start the compressor and fill the tank up to the maximum pressure. If a compressor is not available, use nitrogen tanks and/or small portable compressors.
- 7.4. Open the valve and fill the system up to 1 bar approx. (15 psi); close the valve and check that no leaks are detected in the system.
- 7.5. **Increase the pressure** of the system slowly until you reach the maximum pressure. Keep this pressure for about 1 hour. Test the system when the pressure is 1.5 times higher than the working pressure.
- 7.6. Inspect the system again and check that no leaks or other unusual deformations are visible in the joints.
- 7.7. **Empty** the system.
- 7.8. **ATTENTION: testing and inspection must be carried out only when no one is present in the working area. Wear a safety helmet and protective glasses when inspecting the system. Please follow all safety precautions.**

8. REPAIRS AND MODIFICATIONS

- 8.1. Modifications to the system are quick and easy. We suggest preparing all tools in advance, next to the area where modifications are to be made. By doing so, the downtime of the line is minimized.
- 8.2. If a leak is detected in the system, consult the following table where the most common causes and corresponding remedies are described.
- 8.3. In the case of faulty pieces manufactured by TESEO, please contact our technical department.
- 8.4. **ATTENTION: release pressure from the area of the system to be modified before carrying out repairs, maintenance or modifications. Isolate the area and inform people about maintenance operations.**

| CAUSE OF THE LEAK | CORRECTIVE ACTION (REMEDIAL) |
|--|--|
| O ring seal damage due to incorrect installation, or defective. | Replace the O ring seal. |
| Fitting or outlet plate threads damaged. | Seal with a Teflon band or replace the faulty piece. |
| The drilled hole on the bar is too big or misaligned. | Replace the faulty section of the hollow bar. |
| Extrusion blowholes into the hollow bar. | Replace the defective part. |
| Misaligned mounting of the joint in the corresponding bar seats. | Disassemble the joint and realign the bars. |
| Defects in the seat of o ring of "I" and "T" joints. | Replace faulty joint. |

INSTALLATION OF FLEXIBLE PIPES

1. CONNECTION TO MACHINE

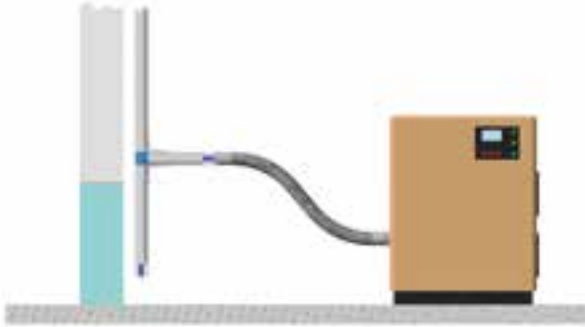

We recommend that the compressor is connected with a flexible pipe to absorb the vibrations due to the machine on every installation.

2. OBSTACLES

We remind you that to avoid any distortion, the bend radiuses of the flexible rubber pipes must not be too sharp to avoid damage it, the flexible pipe mustn't be forced against the obstacle.

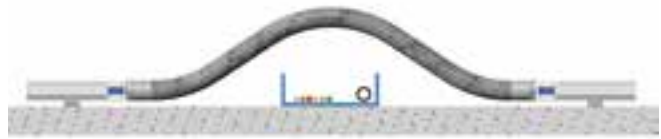

3. CHANGES IN HEIGHT

Hoses can be useful when the changing of level is lower or equal than the encumbrance of two L Joints; However it is recommended when the vertical side of the line can't be fixed.



4. SPECIAL ANGLES

It is useful too when the horizontal angle of the line can't be achieved with others components from our catalogue; however it remains possible to use terminals threaded together from steel components (not recommended) from retail trade.



5. CURVING AT 180°



| Flex Pipe | HBS25 | HBS32 | HBS50 | HBS63 | HBS80 |
|---------------|-------|-------|-------|-------|-------|
| Min Radius mm | 100 | 130 | 200 | 270 | 340 |

| Flex Pipe | AP22 | AP28 | AP36 | AP45 | AP54 | AP68 |
|---------------|------|------|------|------|------|------|
| Min Radius mm | 90 | 100 | 130 | 150 | 200 | 270 |

| | |
|-------------------------------|---------------|
| Material | EPDM |
| Temperature | -30°C ÷ +70°C |
| Available for special request | |

COMPRESSED AIR IS EXPENSIVE: DON'T WASTE IT!

Good tips for new investment

MAKE THE RIGHT CHOICE

You may change your compressor or dryer in future, but your compressed air piping is a fixed utility in your plant.

USE QUALITY PRODUCTS

Original quality piping system will assure reliable performance and expected safety standards in your factory.

CHOOSE THE RIGHT SIZE

The right engineering & sizing of the system is fundamental to save energy, potentially more than any other practice.

INSTALL A LEAK FREE SYSTEM

Modular systems with positive seals will perform better than any threaded conventional tubing.

DON'T FOCUS ON INITIAL COST

The cost of components is only a small part of the total investment. Choose systems with the lowest cost of ownership!

COMPRESSED AIR LIFETIME COSTS

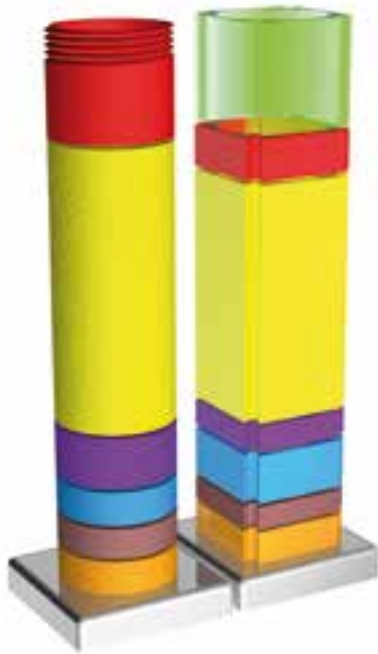

- **MONEY SAVED:** saving due to correct sizing and engineering, optimised working pressure and choice of high quality product.
- **LEAKAGE:** cost of air leaks and inappropriate use of compressed air during the lifetime of the system.
- **ELECTRICITY:** cost of electricity to feed the air compressor.
- **INSTALLATION:** cost of labour for installing the system, for extensions and modifications, for ordinary maintenance.
- **MATERIAL:** cost of pipes and fittings for assembling the system.
- **MAINTENANCE:** cost for running ordinary maintenance of the machines generating compressed air.
- **GENERATION:** cost of machines for generating compressed air (including compressor, receiver, dryer, filters).

Some good general practices...

Prevent and reduce leaks

In a conventional piping system leaks may waste 20-40% of your compressed air. Routinely check your system for leaks.

Reduce air pressure

Reducing the pressure in your system of 1 bar (15 psi) will lead to 7% saving on your annual energy consumption.

Feed compressors with cool air

With 3°C cooler intake air, compressor will save 1% energy to reach the desired working pressure.

Avoid inappropriate use

Check the efficiency of compressed air used for cooling, agitating, mixing or inflating in your factory.

**Contact our technical department for a first quick check-up of your system.
We will help you to focus on the analysis and intervention by giving an assessment of costs and waste.**

DATA FOR PLANT

Agent: Installer:
 Retailer: End user:

Fill in at least 4 fields below to develop the new project:

units Flow rate
 units Teseo diameter
 units Maximum pressure drop
 units Absolute starting pressure
 units Length of the considered network

For complex multi-diameter do sketch on the next page by adding all the notes you want

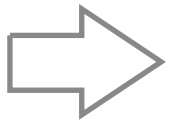

Refine your project:

Compressor/s Power
 c1 Units c2 Units c3 Units c4 Units c5 Units

Area consumption
 z1 Units z2 Units z3 Units z4 Units z5 Units

units Coincidence factor

Type of thread:
 BSP NPT

Drop column*

Diameter:..... Quantity:.....
 Diameter:..... Quantity:.....
 Diameter:..... Quantity:.....

Already have an installation? With these few data we tell you how much it costs!
 And on the purchase of a new plant Teseo calculate the payback!

Product installed: Total development:
 Age of the installation: Ø Pipe:
 Daily working hours: % Losses hypothesized:
 Labor cost: Cost of electricity

In what language do you wish the project to be developed:

Italian English German Spanish

When you want the project:

If you have additional information, you can write them on the next page, more information allow us to better develop your project.

* Or create your drop column using the instructions on page 30 (HBS system) and page 53 (AP system).

For any special product that you have to realize contact the technical department Teseo Italy.

NOTES:

DRAFT:

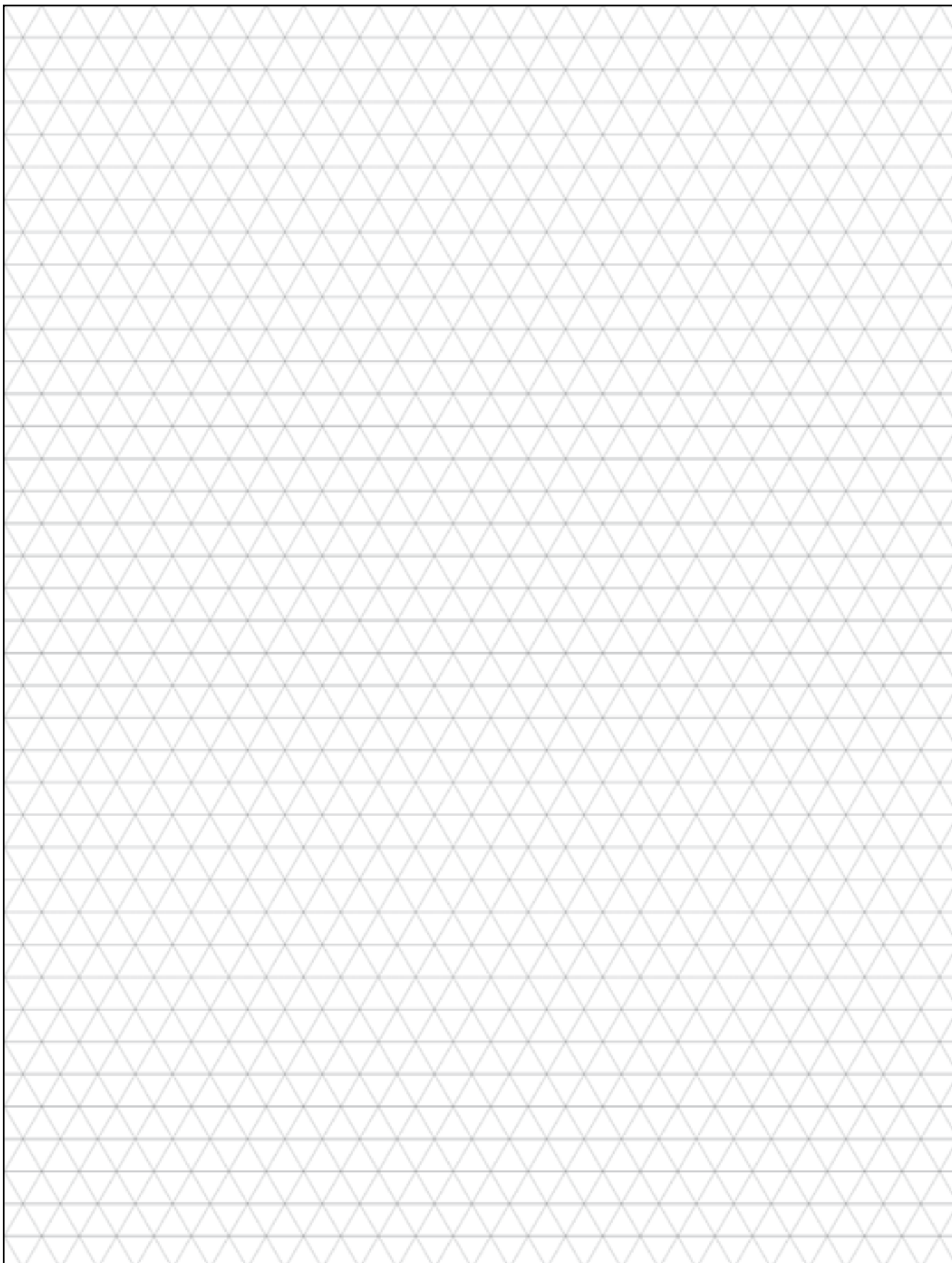

IRELAND

ireland@teseoair.com

DEUTSCHLAND

www.teseoair.de
deutschland@teseoair.com

IBERICA

www.teseoiberica.eu
www.teseoiberica.com
teseo@teseoiberica.com

UNITED STATES

www.teseo.us
www.teseoair.us

TESEO

www.teseoair.com
www.teseoair.it
teseo@teseoair.com

BENELUX

www.teseobenelux.com
teseo@teseobenelux.com

MEXICO

www.teseo.com.mx

UNITED KINGDOM

www.teseouk.eu
uk@teseoair.com

CANADA

www.teseo.ca
canada@teseoair.com

COLOMBIA

www.teseo.co
colombia@teseoair.com

FRANCE

www.teseo.fr
france@teseoair.com

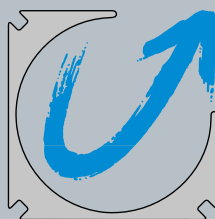
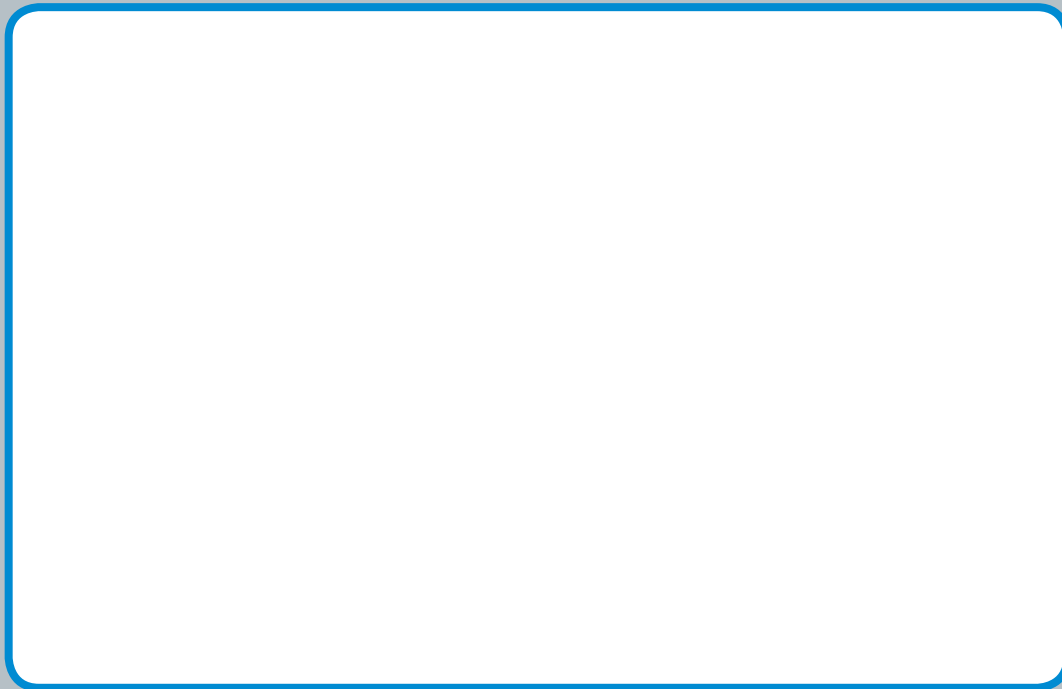

TESEO[®]

**Teseo srl - Via degli Oleandri, 1
25015 Desenzano del Garda (BS) - Italy
Tel. +39 030 9150411 - Fax +39 030 9150419
www.teseoair.com - teseo@teseoair.com**

EN



CATALOGO OMAGGIO NON DESTINATO ALLA VENDITA
Graphics: ALYKE' COMUNICAZIONE - TESEO TECHNICAL DEPT

COD. 995 518 018 - Pubbl: OTTOBRE 2018